

INSTALLATION INSTRUCTIONS

Monocrystalline Solar Modules

LGxxxS1C(W,K)-G3/-A3/-B3

LGxxxS8C(W,K)-G3/-A3/-B3

LGxxxN1C(W,K)-G3/-A3/-B3

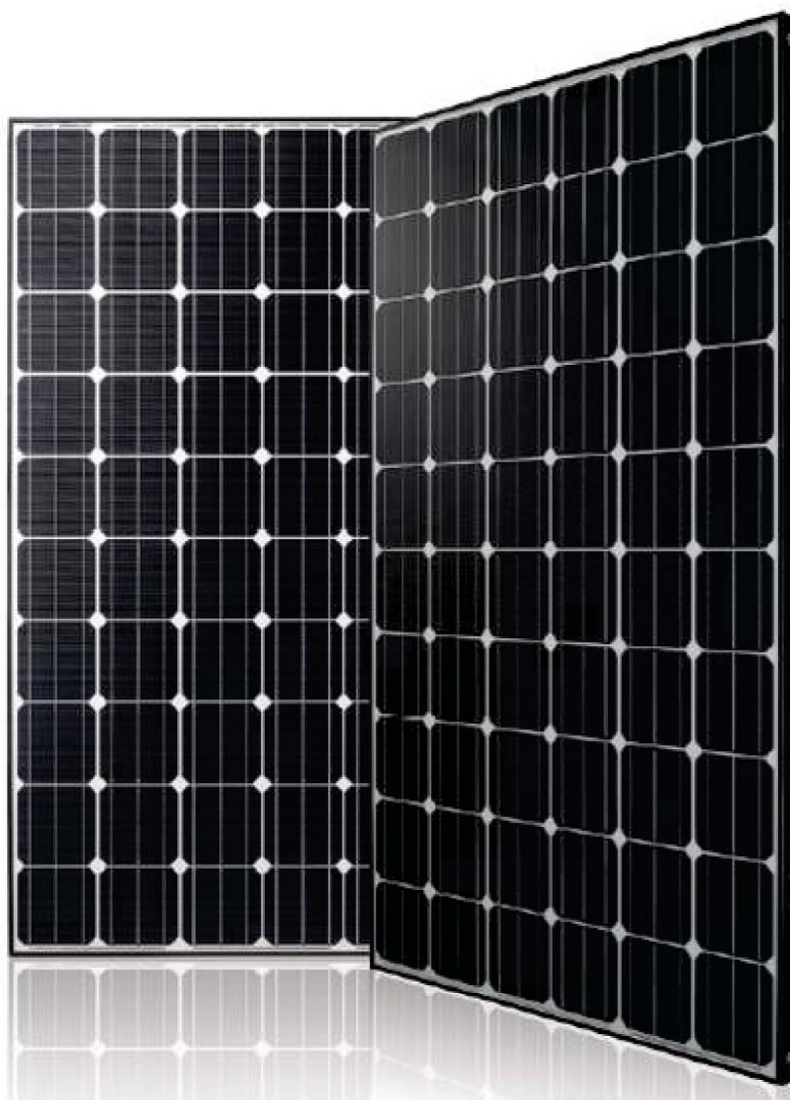

TABLE OF CONTENTS

Safety	4
Before & After Installation	6
Before Installation	6
After Installation	7
Electrical Installation	8
Caution	8
Electrical Connections	8
Series Connection	9
Parallel Connection	9
General Wiring	10
Earth Grounding	11
Mechanical Installation	12
Module Mounting	12
Site Consideration	12
Mounting Methods	13
Disclaimer of Liability / Disposal	17
Disclaimer of Liability	17
Disposal	17
Transporting and Storage	18

EN

SAFETY

SAFETY

The instructions related to the safety indicated in the following are for preventing unexpected danger or damage in advance by safely and exactly using the product.

DANGER

Non-compliance of the instructions may immediately cause serious injury or death.

WARNING

Non-compliance of the instructions may cause death or serious injury to the user.

CAUTION

Non-compliance of the instructions may cause injury or property damage to the user.

DANGER

1. Do not contact with electrically active parts of the module, such as terminals, regardless of connection of the module. It may result in spark or lethal electric shock.

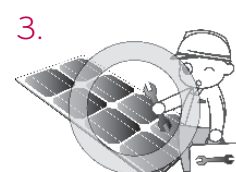
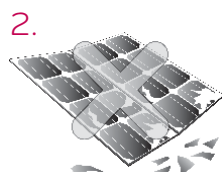
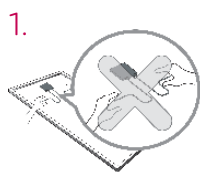

2. Please don't use the module with the broken window or the torn back side. There is a danger of electric shock.

WARNING

1. Please perform works in the dry condition and use only dry tools. Do not handle the wet modules without protection equipment. It may result in safety accident.

2. Damaged module must be treated with safety protection equipment. It may result in injury.

3. Do not approach the damaged or broken module unless you are an expert. It may result in serious injury.

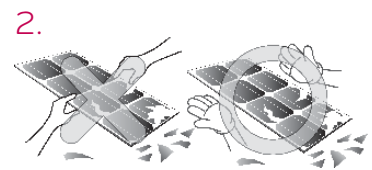
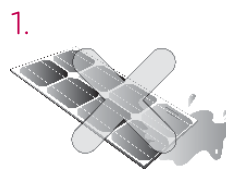

SAFETY

CAUTION

1. Please use proper equipment, connector, wire and buttress for system configuration of the module. It may result in damage or failure of the product.
2. Do not perform installation in rainy, heavily windy or snowy days. It may result in safety accident.
3. Do not make holes in the frame or glass of the module. It may decrease the strength of the frame or break the glass.
4. Do not touch the glass surface or frame of the solar module after installation of the module. It may result in injury.
5. Do not locate a heavy object onto the module. Do not stand on or step on the module. Do not drop or suddenly lay down the module. It may result in injury.
6. Do not scratch the coating surface of the frame. It may decrease the strength due to corrosion of the frame.
7. Do not concentrate sunlight on the module surface. It may result in damage of the product.
8. Do not apply a shock to the junction box of the module or pull the cable. Do not remove the labels attached to the module. It may result in damage of the product.

9. If the installing structure has a curved surface e.g. arch type as shown in the below picture, do not forcefully modify the module in installation when connecting it with the structure. Please install the module in the place where the structure has been completely set up because deformation of the structure may cause deformation of the product when performing installation by using a crane, etc. after assembling the module to the installing structure.

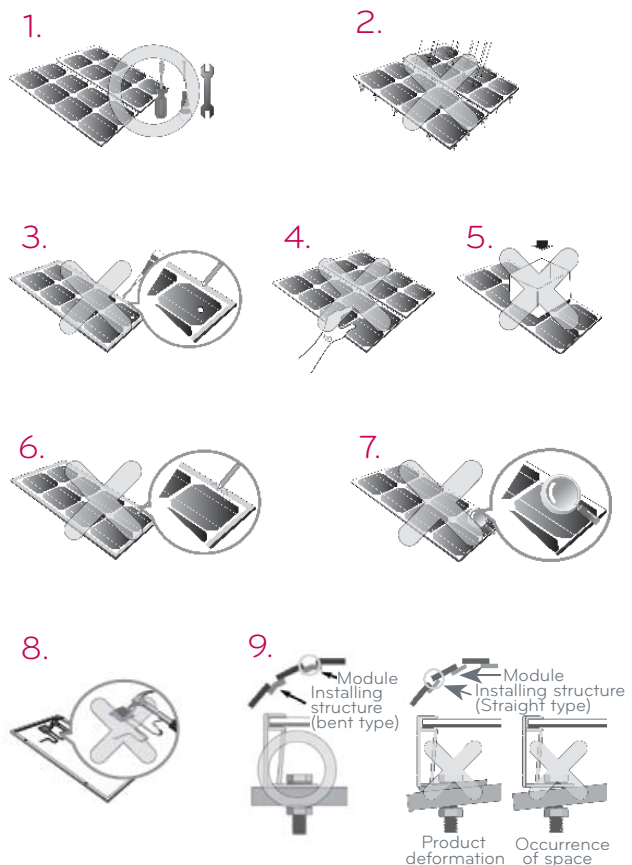

BEFORE & AFTER INSTALLATION

BEFORE & AFTER INSTALLATION

Before Installation

Please carefully read this manual before installation.

- Solar module installation should be performed by an authorized installer for the safety and maintenance of the system.
- All installation instructions should be clearly understood before attempting installation.
- Do not twist, pull, or scratch the cable attached to the solar module.
- Do not touch the solar module with bare hands. It may result in a burn or injury.
- Do not drop the solar module and cause an excessive load on the solar module.
- Do not disassemble the solar module.
- After installation or repair, check whether the solar module operates properly or not.
- In case the currently used solar module or the parts applied to the solar module have been replaced, check whether the changed solar module is properly operated or not. The newly replaced solar module and its parts must be the same solar module (module name) and parts with the current solar module.
- Please contact the local office to confirm the regulations and to obtain permission.
- Do not let anyone approach the solar module who has little knowledge of solar modules or on the measures to take when solar modules are damaged in order to avoid the risk of injury or electrical shock.
- Do not locate the solar module horizontally, as this may cause dirt or white efflorescence (glass deformation).
- Modules produce voltage even when not connected to an electrical circuit or load.
- Modules are intended for outdoors, land based applications only. Modules are not intended for indoor use or application on moving vehicles of any kind.
- Reflection from external environments such as snow, water or other surfaces can increase the power generated by the module.
- Industry standard rated specifications are made at conditions of 1000 W/m² irradiance and 25°C solar cell temperature. Colder temperatures can substantially increase voltage and power.
- Keep the solar module and system away from children when installing.
- Keep the module packed in the carton until the time of installation.

BEFORE & AFTER INSTALLATION

EN

- Make sure flammable gases are not generated near the installation site.
- Do not work alone. Please work as part of a team of two or more people.
- Wear a safety belt if working high above the ground.
- Contact with electrically active parts of the modules, such as terminals, can result in burns, sparks and lethal shock whether the module is connected or disconnected.
- Even partial shadowing can substantially reduce module and system output.
- Care must be taken to avoid low tilt angles which may cause dirt to buildup on the glass against the frame edge.
- Dirt build-up on the surface of the module can cause active solar cells to be shaded and electrical performance to be impaired.
- Always keep the back surface of the module free from any foreign objects or structural elements which could come into contact with the module, especially when the module is under mechanical load.
- For permission to use mounting methods not described in the Installation Instructions please consult LG Electronics. Failure to do so will void the warranty and module certification.

After Installation

- Plug the connector in tightly and ensure that the wiring properly works.
- It is advisable to conduct periodic inspection of the modules for damage to front glass, back sheet, frame, junction box, or external electrical connections.
- Check electrical connections for loose connections and corrosion.
- Photovoltaic modules can operate effectively without ever being washed, although removal of dirt from the front glass can increase output.
- Water, ethanol or a conventional glass cleanser with a micro-fiber cloth can be used for regular washing or rinsing of the front glass to remove dust, dirt or other deposits.
- No aggressive and abrasive cleansers or chemicals such as alkali chemicals including ammonia based solution should ever be used on the treated front glass.
- Always wear rubber gloves for electrical insulation while maintaining, washing or cleaning modules.
- Deposits of foreign material on the frame surface can be cleaned using a wet sponge or cloth and dried in air or by using a clean chamois.
- Perform the wiring work by connecting the connector and wires to stand away from the roof or ground.

ELECTRICAL INSTALLATION

ELECTRICAL INSTALLATION

Caution

- Avoid all electrical hazards when installing, wiring, operating and maintaining a module.
- Do not use modules of different electrical or physical configurations in the same system.
- Match the polarities of cables and terminals when making the connections; failure to do so may result in damage to the module.
- When reverse currents can exceed the value marked on the name plate, a properly rated and certified overcurrent device (fuse or circuit breaker) must be connected in series with each module or string of modules.
- The rating of the over-current device shall not exceed the maximum series fuse rating marked on the name plate.
- The module contains factory installed bypass diodes located inside the junction box.
- When installing the system, it is recommended to install the lightning rod to protect the system.
- The junction box should not be opened. Opening the junction box may void the warranty.
- Modules with a suspected electrical problem should be returned to LG Electronics for inspection and possible repair or replacement as per the warranty conditions provided by LG Electronics.

Electrical Connections

- Modules may be connected in series and/or parallel to achieve the desired electrical output as long as certain requirements are met.
- Please use only the same type of modules in a combined source circuit.
- Do not disconnect the module under load.
- Shock hazard can occur near the solar modules connection means.

ELECTRICAL INSTALLATION

EN

Series Connection

- The solar modules may be wired in series to produce the desired voltage output.
 - The current of each module connected in series should be same.
 - **Do not exceed 80% of maximum system voltage.**
 - The maximum number of series connected modules can be determined by basis on max. system voltage, the 125 % safety factor, and the module V_{oc} which can be checked in the related data sheet.
 - Maximum solar module configuration:
 - LGxxxS1Cy-G3, xxx = 230...240
maximum 21 solar modules in series
 - LGxxxS1y-G3/-A3/-B3, xxx = 245...280
maximum 20 solar modules in series
 - LGxxxS8y-G3/-A3/-B3, xxx = 200...210
maximum 26 solar modules in series
 - LGxxxN1y-G3/-A3/-B3, xxx = 250...305
maximum 20 solar modules in series
- y = C, W, K, all at temperature: 25 °C:

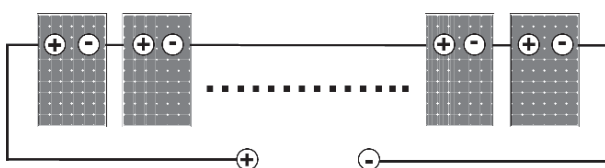

Series connection for more voltage

Parallel Connection

- The solar modules may be combined in parallel to produce the desired current output.
 - When modules are combined in parallel, the total current is equal to the sum of currents from each module.
 - The voltage of each module connected in parallel should be same.
 - When connecting plural strings of modules in parallel every series string or solar module must be fused prior to combining with other strings.
 - Bypass diodes are factory installed in the solar modules.
 - Please refer to the applicable regional and local codes for additional fusing requirements and limitations on the maximum number of solar modules in parallel.
 - Maximum parallel strings without proper measures, e.g. fuse 20 A and/or blocking diode: 1 string
- Parallel configuration is not limited if proper measures are taken to block the reverse current flow, e.g. fuses for the protection of the module and cables from overcurrent and/or blocking diodes for prevention of unbalanced string voltage.

ELECTRICAL INSTALLATION

- A multiplying factor is required for increased output of the photovoltaic modules. Under normal conditions, a photovoltaic module is likely to experience conditions that produce more current and/or voltage than reported at standard test conditions. Accordingly, the values of I_{sc} and V_{oc} marked on this photovoltaic module should be multiplied by a factor of 125 % when determining component voltage ratings, conductor ampacities, fuse sizes, and size of controls to the photovoltaic output.
- Depending on national directives additional safety factors might be applicable for overcurrent protection.

General Wiring

- LG Electronics recommends that all wiring be double insulated with a minimum rating of 90 °C.
- All wiring should use a flexible copper (Cu) conductor.
- The minimum size should be determined by the applicable codes. LG Electronics recommends a size not smaller than 4 mm².

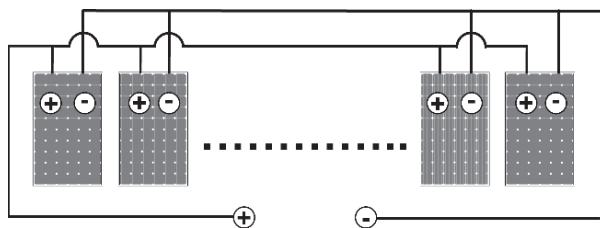

Parallel connection for more current

ELECTRICAL INSTALLATION

EN

Earth Grounding

- The solar modules from LG Electronics meet the conditions of Safety Class II. Therefore grounding is not mandatory. However grounding is recommended. Also equipotential bonding must be realized. The national directives must be respected.
- Specific information on the solar module dimensions and location of grounding holes is provided in the related data sheet.
- One M4 stainless steel bolt, two flat washers, one star washer, one cup washer, one spring washer, one nut, and 12 AWG Cu wires are recommended per solar module.
- There is an earth hole in the center of the module frame. Using this hole, an earth conductor and the solar module frame may be recommended to connect and earth as the below drawing.

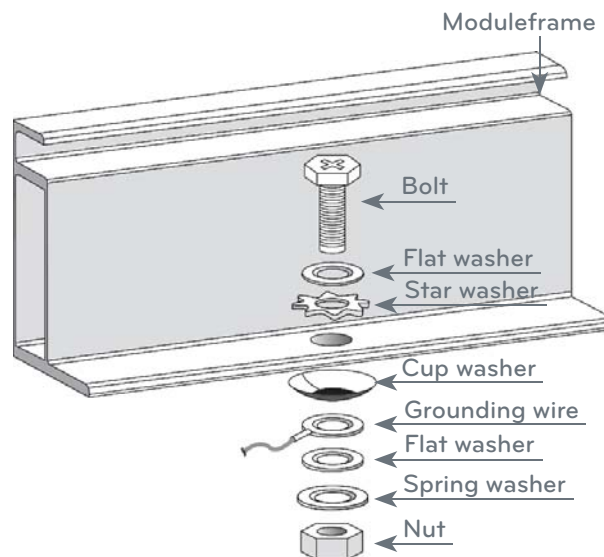

MECHANICAL INSTALLATION

MECHANICAL INSTALLATION

Module Mounting

- The guarantee for solar modules from LG Electronics is contingent upon modules being mounted in accordance with the requirements described in this section.
- The solar modules are in Application Class A and have the Safety Class II. Therefore they can be operated in systems with 120 V DC and higher. General access is not restricted.

Site Consideration

Solar modules from LG Electronics should be mounted in a location that meets the following requirements.

Operating Temperature

- Maximum Operating Temperature: +90 °C
- Minimum Operating Temperature: -40 °C

Design Strength

- Snow loads (Front side): 5.400 Pa
- Wind loads (Rear side): 2.400 Pa

Operating Environments

- The solar modules from LG Electronics can be operated in a location where they could come in contact with salt water or ammonia, if they have been tested successfully for these operating conditions. Please see related certificates. Please get from LG Electronics an approval for increased conditions.

MECHANICAL INSTALLATION

EN

Mounting Methods

General Information

- Select the appropriate orientation to maximize sunlight exposure.
- In order to prevent water from entering the junction box, which could present a safety hazard, module should not be mounted such that the front/top glass faces downward.
- Clearance between the solar module frames and structures such as roofs or ground is required to prevent wiring damage and to allow air to circulate behind the solar module. The recommended standoff height is a minimum of 100 mm.
- When installed on a roof, the solar module must be mounted over a fire-resistant roof covering rated for the application. The fire resistance of the solar module from LG Electronics is Class C after ANSI/UL790.
- The solar module is only IEC listed for use when its factory frame is fully intact.
- Do not remove or alter the solar module frame.
- Creating additional mounting holes may damage the solar module and reduce the strength of the frame.
- A 6 mm gap between module frames should be allowed to avoid tension from thermal expansion.
- The solar module may be mounted using the following methods (torque: 8 - 12 Nm).
- When installing modules in heavy snow areas, it is recommended to take an appropriate countermeasure to prevent possible damages to the lower side frame by slipping snow (e. g. attach supporting part to the lowest modules).

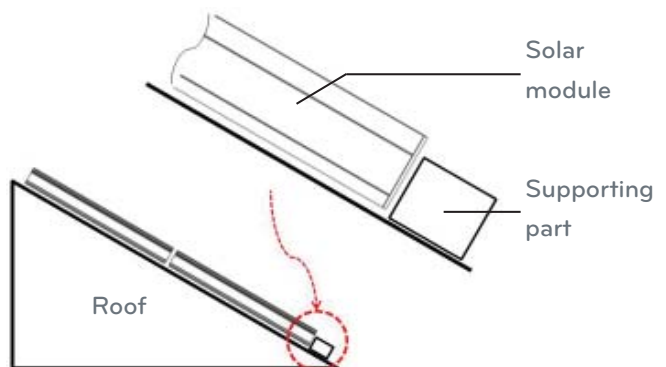

MECHANICAL INSTALLATION

Mounting by using frame bolts holes

- Secure the solar module to the structure using the factory mounting holes.
- Four M6 stainless steel bolts, eight flat washers, four spring washers, and four nuts are recommended per solar module.
- The module may be fastened to a support using both the outer and inner bolt holes of the frame.
- Each module should be securely fastened at a minimum of 4 points on two opposite sides.

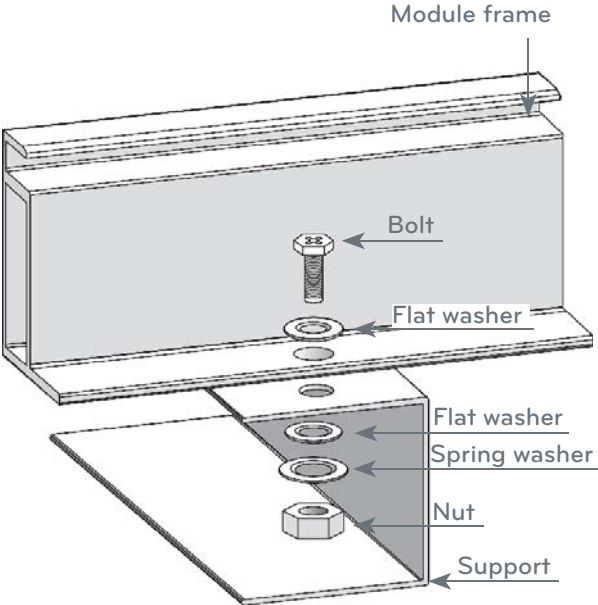

- Specific information on the solar module dimensions and location of mounting holes is provided in the related data sheet.
- Tighten the bolt securely using this combination. Place spring washer between flat washer and nut.

Mounting by using clip or clamps

- The module may be fastened to a support using clips or clamps on both the long edge and the short edge of the modules.
- Specific information on the solar module dimensions and location of clipping is provided in the related data sheet.

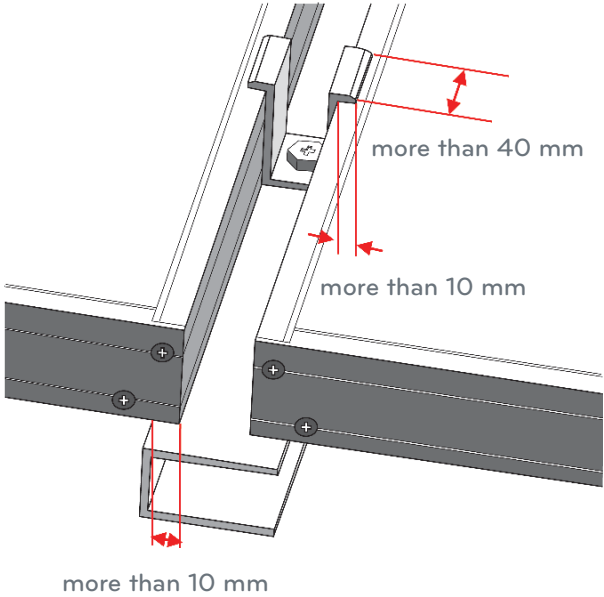

MECHANICAL INSTALLATION

EN

LGxxxS1C(W,K)-G3/-A3/-B3, LGxxxN1C(W,K)-G3/-A3/-B3

Mounting Type

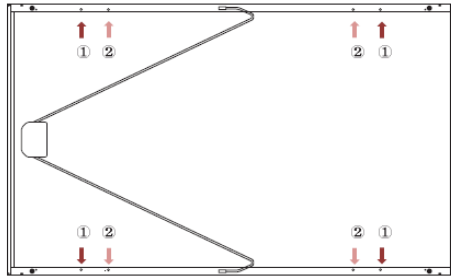

Use four mounting holes on two opposite sides.

Clamping Type
(Long Side)

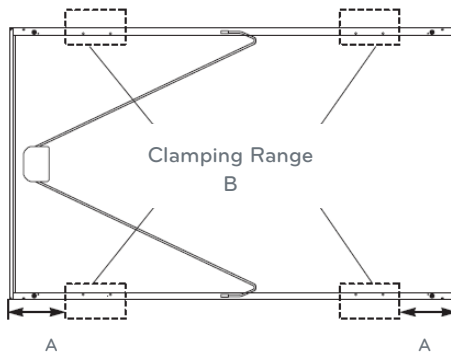

Use four clamps on the long frame.
2400 Pa: A = 100 mm, B = 450 mm
5400 Pa: A = 270 mm, B = 230 mm

Clamping Type
(Short Side)

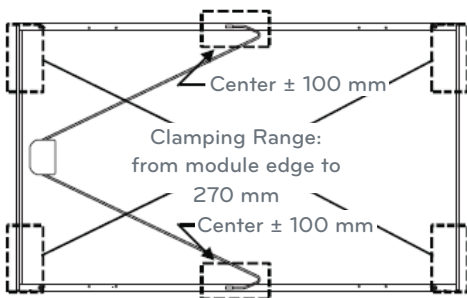

Use four clamps on the short frame and two clamps at the center of the long frame.

This method is not tested by IEC/UL.

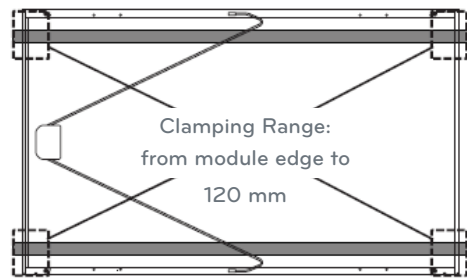

Use four clamps on the short frame.
This installation is allowed in the following cases:
1. Slope roof: If module is installed parallel to the rooftop
2. Flat roof: If installed with an additional stand such as wind shield or deflector

MECHANICAL INSTALLATION

LGxxxS8C(W,K)-G3/-A3/-B3

Mounting Type

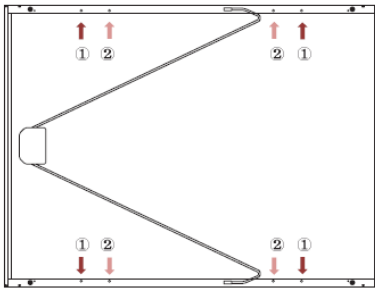

Use four mounting holes on two opposite sides.

Clamping Type
(Long Side)

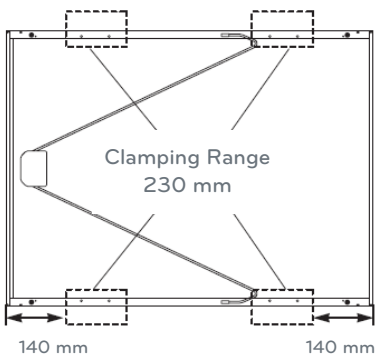

Use four clamps on the long frame.

Clamping Type
(Short Side)

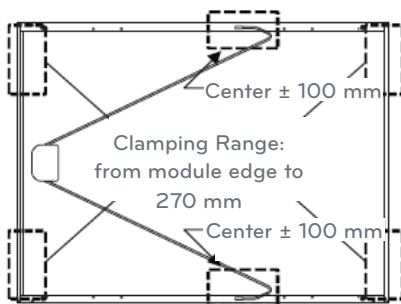

Use four clamps on the short frame and two clamps at the center of the long frame.

This method is not tested by IEC/UL.

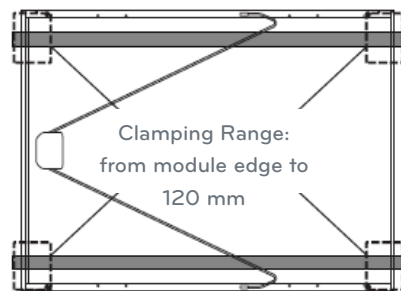

Use four clamps on the short frame.

This installation is allowed in the following cases:

1. Slope roof: If module is installed parallel to the rooftop
2. Flat roof: If installed with an additional stand such as wind shield or deflector

DISCLAIMER OF LIABILITY / DISPOSAL

EN

DISCLAIMER OF LIABILITY / DISPOSAL

Disclaimer of Liability

- Since the use of this Installation Instructions and the conditions or methods of installation, operation, use and maintenance of the module are beyond the control of LG Electronics, LG Electronics does not assume responsibility and expressly disclaims liability for loss, damage, injury or expense arising out of or in any connection with such installation, operation, use or maintenance of the module.
- LG Electronics assumes no responsibility for any infringement of patents or other rights of third parties that may result from use of the module. No license is granted by implication or otherwise under any patent or patent rights.

Disposal

- All solar modules should be disposed separately from the municipal waste stream via designated collection facilities appointed by the government or the local authorities.
- The correct disposal of the solar modules will help prevent potential negative consequences for the environment and human health.
- Please contact the city office, the disposal service, the company where the product has been purchased or LG Electronics at the address given overleaf for more information about the disposal or recycling of the solar modules.

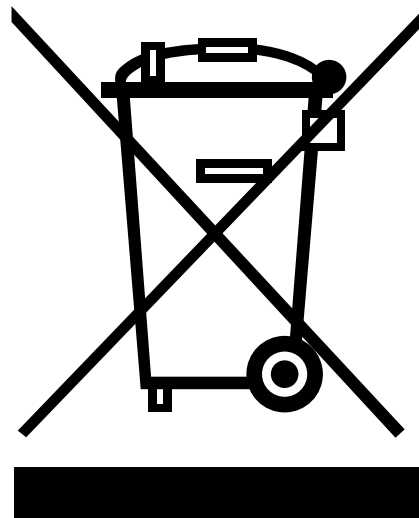

TRANSPORTING AND STORAGE

TRANSPORTING AND STORAGE

- Do not loose the banding, when module is transported by truck, ship and etc. In case of loose banding, module will be shaken, which may cause damage, like glass breaking.
- Do not stack on more than one pallet. The maximum height is two pallets. Severe stacking can give stress to the module and may cause product damage.

This document is subject to change without notice.
LG, LG logo and Life's Good are trademarks of LG Electronics, Inc. worldwide.
Trademarks and intellectual properties of LG Electronics, Inc. are protected by international copyright laws.
In case of conflict with other languages of this Installation Instruction the German version shall prevail.

Document: II-G3A3B3-IEC-V4-EN-201405



More information available at
service-solar@lge.de
www.lg-solar.com



LG Electronics Deutschland GmbH
Berliner Straße 93
40880 Ratingen,
Germany
Tel. +49 (0) 21 02/70 08-0
Fax +49 (0) 21 02/70 08-777