



**KACO blueplanet  
hybrid 10.0 TL3**

## Operating Instructions

■ English translation of German original

### Important safety instructions

These instructions form part of the product and must be carefully read, observed and stored in a place which is freely accessible at all times.

## Legal provisions

The information contained in this document is the property of KACO new energy GmbH. Publication, in whole or in part, requires the written permission of KACO new energy GmbH.

### KACO warranty

You can download the current warranty conditions on the Internet at <http://www.kaco-newenergy.com>.

### Definitions on product designations

In these operating instructions, the product "blueplanet hybrid 10.0 TL3" is referred to as the device for ease of reading.

### Trademarks

All trademarks are recognised, even if not explicitly identified as such. A lack of identification does not mean that a product or designation/logo is free of trademarks.

## Table of contents

<b>1</b>	<b>General information.....</b>	<b>5</b>
1.1	About this document.....	5
1.2	Design features .....	5
1.2.1	Symbols used .....	5
1.2.2	Safety warnings symbols guide.....	6
1.2.3	Additional information symbols .....	6
1.2.4	Symbols for instructions .....	6
1.3	Target group.....	6
<b>2</b>	<b>Safety.....</b>	<b>7</b>
2.1	Proper use .....	7
2.2	Protection concepts .....	8
<b>3</b>	<b>Unit description .....</b>	<b>9</b>
3.1	Functionality.....	9
3.2	Integrated energy management .....	9
3.2.1	Operation mode: Self-consumption optimisation with load compensation (Self-Consumption) .	9
3.2.2	Operation mode: Battery Charging.....	9
3.2.3	Operation mode: External presetting (External) .....	9
3.3	Integration diagram .....	10
3.4	Compatible accessories.....	11
3.4.1	KACO blueplanet hy-switch .....	11
3.4.2	Released battery storage units .....	11
<b>4</b>	<b>Technical data .....</b>	<b>12</b>
4.1	General data.....	12
4.2	Detailed technical data .....	12
4.3	Environmental data.....	13
<b>5</b>	<b>Delivery and transport .....</b>	<b>14</b>
5.1	Scope of delivery .....	14
5.2	Transporting the device .....	14
5.3	Installation tool .....	15
<b>6</b>	<b>Assembly and preparation .....</b>	<b>16</b>
6.1	Required material.....	16
6.2	Choosing the installation location.....	17
6.3	Unpacking the device .....	18
6.4	Securing the wall bracket .....	18
6.5	Installing and securing the device .....	20
<b>7</b>	<b>Installation.....</b>	<b>22</b>
7.1	General information.....	22
7.2	Information regarding electrical connections .....	23
7.3	Connecting the device to the power grid.....	24
7.3.1	Connecting the device to a standalone grid .....	25
7.3.2	Connecting the device for standby power operation .....	26
7.3.3	Permissible connectors .....	27
7.3.4	AC cable fitting assembly.....	28

7.3.5	Connecting the connectors .....	29
7.3.6	Technical data .....	30
7.4	Connecting the PV generator to the device.....	31
7.4.1	Designing the PV generator.....	31
7.4.2	Configuring the DC connectors.....	33
7.4.3	Checking the PV generator for a ground fault.....	34
7.4.4	Connecting the PV generator .....	34
7.5	Connecting the battery storage unit to the device.....	35
7.5.1	Checking the battery storage unit.....	35
7.5.2	Configuring the DC connectors.....	36
7.5.3	Connecting the battery storage unit .....	36
7.6	Connecting the KACO blueplanet hy-switch to the device .....	37
<b>8</b>	<b>Start-up .....</b>	<b>39</b>
8.1	Hardware commissioning .....	39
8.2	Configuration with the blueplanet hy-sys software .....	39
8.3	Display.....	40
8.3.1	Start display.....	40
8.3.2	Operating display .....	41
8.3.3	Selection menu.....	43
8.3.4	Switching off the inverter .....	47
8.3.5	Warning/Error .....	48
8.3.6	Warning display.....	49
8.4	Update .....	49
<b>9</b>	<b>Maintenance and troubleshooting .....</b>	<b>50</b>
9.1	Visual inspection .....	50
9.2	Cleaning .....	51
9.2.1	Cleaning the housing .....	51
9.3	Warning messages / error messages / information .....	52
9.3.1	List of warning messages.....	52
9.3.2	List of error messages.....	55
	List of displayed information .....	57
9.4	Other faults .....	58
<b>10</b>	<b>Decommissioning and dismantling .....</b>	<b>59</b>
10.1	Switching off the device.....	59
10.2	Uninstalling the device .....	60
10.2.1	Disconnecting the DC connector .....	61
10.2.2	Disconnecting the communication cable .....	61
10.2.3	Disconnecting the AC connector .....	61
10.3	Disassembling the device.....	62
10.4	Packaging the device.....	62
10.5	Storing the device .....	62
<b>11</b>	<b>Disposal.....</b>	<b>63</b>
<b>12</b>	<b>Service and warranty.....</b>	<b>63</b>

# 1 General information

## 1.1 About this document

### Other applicable documents

During installation, observe all assembly and installation instructions for components and other parts of the system. These instructions also apply to the equipment, related components and other parts of the system.

Some of the documents required for the registration and approval of your system are included with the operating instructions.

Links to more detailed information can be found at [www.kaco-newenergy.com](http://www.kaco-newenergy.com).

Document title	Document type
Technical data sheet	Technical information on the product
hy-sys software documentation	Application note – Operating the software tool for monitoring and configuration
Grid protection and safety parameters Default parameters	Application note
Grid standby operation	Application note
Software package hy sys	ZIP files for current software
EU Declaration of Conformity Country-specific certificates Certification for specific subassembly	Certificates

### Storing the documents

These instructions and other documents must be stored near the system and be available at all times.

- The current version of the operating Instructions can be downloaded at [www.kaco-newenergy.com](http://www.kaco-newenergy.com).

### English translation of German original

These operating instructions have been produced in several languages. The German-language version of the operating instructions is the original version. All other language versions are translations of the original operating instructions.









### WARNING

**Improper handling of the device can be hazardous!**

- You must read and understand the operating instructions in order to install and use the device safely!

## 1.2 Layout of Instructions

### 1.2.1 Symbols used

	General hazard		Fire and risk of explosion
	Electrical voltage		Risk of burns
	Earthing - ground conductor		Waiting time after discharge

 **Authorized electrician** The tasks indicated with this symbol may only be carried out by an authorised electrician!

## 1.2.2 Safety warnings symbols guide



### DANGER

#### High risk

Failure to observe this warning will lead directly to serious bodily injury or death.



### WARNING

#### Potential risk

Failure to observe this warning may lead to serious bodily injury or death.



### CAUTION

#### Low-risk hazard

Failure to observe this warning will lead to minor or moderate bodily injury.

### CAUTION

#### Risk of damage to property

Failure to observe this warning will lead to property damage.

## 1.2.3 Additional information symbols



### NOTE

#### Useful information and notes

Information that is important for a specific topic or objective, but that is not safety-relevant.

## 1.2.4 Symbols for instructions

↪ Prerequisite for use

1 Carry out the next step

1. Additional action sequence

⇒ Interim result of the action

» End result

## 1.3 Target group

All activities described in the document may only be carried out by specially trained personnel with the following qualifications:

- Knowledge about how an inverter functions and operates.
- Training in the handling of hazards and risks during the installation and operation of electrical devices and systems.
- Education concerning the installation and start-up of electrical devices and systems.
- Knowledge of applicable standards and directives.
- Knowledge and adherence to this document with all safety notices.

## 2 Safety

Before using the product for the first time, please read these safety instructions carefully.



### DANGER

**Lethal voltages are still present in the connections and cables of the device even after the device has been switched off and disconnected!**

Severe injuries or death may occur if the cables and/or terminals/busbars in the device are touched.

- › The device must be mounted in a fixed position before being connected electrically.
  - › Comply with all safety regulations and current technical connection specifications of the responsible power supply company.
  - › The device is only permitted to be opened or serviced by a qualified electrician.
  - › Switch off the grid voltage by turning off the external circuit breakers.
  - › Check that all AC and DC cables are completely free of current using a clip-on ammeter.
  - › Do not touch the cables and/or terminals/busbars when switching the device on and off.
- 
- › Keep the device closed when in operation.

The electrician is responsible for observing all existing standards and regulations. The following applies:

- Keep unauthorised persons away from the device and/or system.
- In particular, observe standard <sup>1</sup>"Requirements for special types of premises, rooms and installations - Solar photovoltaic (PV) power supply systems" in the respective regionally applicable version.
- Ensure operational safety by providing proper grounding, conductor dimensioning and appropriate protection against short circuiting.
- Observe all safety instructions on the product and in these operating instructions.
- Switch off all voltage sources and secure them against being inadvertently switched back on before performing visual inspections and maintenance.
- When taking measurements on the live device:
  - Do not touch the electrical connections
  - Remove all jewellery from wrists and fingers
  - Ensure that the testing equipment is in safe operating condition.
- Modifications to the surroundings of the device must comply with the applicable national and local standards.

### 2.1 Proper use

The device is a transformerless PV inverter which converts the direct current of the PV generator into grid-compatible three-phase alternating current and then feeds the three-phase alternating current into the public power grid. In addition, the device consists of a bidirectional, transformerless inverter for charging and discharging released battery storage.

The device is built using state-of-the-art technology and in accordance with the recognized safety rules. Nevertheless, improper use may cause lethal hazards for the operator or third parties, or may result in damage to the product and other property.

<sup>1</sup>

Country	Standard
EU	Harmonised document - HD 60364-7-712 (European implementation of the IEC standard)

Examples of standards specific to business premises

The device is intended for use in air-conditioned indoor rooms and may only be used in countries for which it has been approved or for which it has been released by KACO new energy and the grid operator.

Operate the device only with a permanent connection to the public power grid. The country and grid type selection must be commensurate with the respective location and grid type.

The requirements of the grid operator must be met for grid connection to take place. The permission of the relevant authorities may also be required in order to secure authorisation to connection to the grid.

The enclosed documentation is an integral part of the product. The documentation must be read, observed and stored in a place which is freely accessible at all times.

The name plate must be permanently attached to the product.

Any other or additional use of the device shall be regarded as improper. This includes:

- Use of a distribution system that is not described (grid type)
- Use in the medical field
- Use of sources other than PV-strings.
- Mobile use
- Use in rooms where there is a risk of explosion
- Use in direct sunlight, rain or a storm or other harsh environmental conditions
- Use in an outdoor area that does not meet the environmental conditions set down in Technical Data > Environmental Data.
- Operation outside the specification intended by the manufacturer
- Overvoltage of over 1000 V on the DC connection
- Modifying the device
- Usage of unreleased battery storage

## 2.2 Protection features

The following monitoring and protection functions are built-in:

- Overvoltage conductor / varistor to protect the power semiconductors from high-energy transients on the grid and generator sides.
- Device temperature monitoring system
- EMC filter to protect the inverter from high-frequency grid interference
- ISO/AFI detection of an isolation fault on the generator.



## 3 Description of the device

### 3.1 Mode of operation

The device ensures the supply of the consumers in the household from three different sources: photovoltaics, energy storage unit and the public power grid. If there is sufficient solar radiation on the photovoltaic system and thus a certain minimum voltage is applied to the device, the start process begins. The feed-in process begins once the PV generator has passed the insulation test and the grid parameters are within the requirements imposed by the grid operator for a specific monitoring time. The inverter remains in operation as long as it is supplied from the photovoltaic system or battery storage unit. If the supply voltage is too low, it shuts down until the voltage of the photovoltaic system reaches the minimum value again.

The power of the photovoltaic system is used to supply consumers and charge the energy storage unit. This means that the energy generated can be used to supply loads with a time delay. If sufficient power cannot be provided by the photovoltaic system and the energy storage unit, the missing energy is taken from the public grid.

In the event of a utility grid failure, the device can establish a backup power supply as long as it is supplied from the photovoltaic system and the battery storage. This function requires the KACO blueplanet hy-switch as a grid disconnection point.

It is possible to use both integrated energy management and suitable external energy management. The selection is made in the blueplanet hy-sys software belonging to the device.

### 3.2 Integrated energy management

The device has integrated energy management. It is designed for mains parallel operation with load compensation. To use load compensation, the KACO blueplanet hy-switch is required as measuring point. The settings for integrated energy management are made in the blueplanet hy-sys software.

#### 3.2.1 Operation mode: Self-consumption optimisation with load compensation (Self-Consumption)

If the photovoltaic system supplies energy, priority is given to connected loads. If the photovoltaic system has a surplus of energy, the energy storage unit is charged with it. When the energy storage unit is fully charged and there is still a surplus of energy, this energy is fed into the public grid. If the charging capacity of the energy storage unit has a limiting effect, it can be fed into the public power grid in parallel with the storage unit charging. The feed-in power into the public power grid can be limited to a freely selectable maximum power during installation. If the power of the photovoltaic system is not sufficient to supply the load, the energy storage unit is discharged to fully supply the load. If the discharge capacity of the energy storage unit is not sufficient, energy is taken from the public power grid.

#### 3.2.2 Operation mode: Battery Charging

Priority battery charging is used to maximise the charge level of the energy storage unit. If the photovoltaic system supplies energy, priority is given to connected loads, provided this is possible by the hardware for load compensation. The excess energy is used to charge the energy storage unit with the maximum possible power. If there is an energy surplus, this energy is fed into the public grid. The maximum photovoltaic feed-in power into the public grid can be set by the installer.

#### 3.2.3 Operation mode: External presetting (External)

In this operating mode, the hybrid inverter is controlled by an external energy management system. In this case, compliance with the relevant standards must be ensured by the system operating company.

### 3.3 Integration diagram

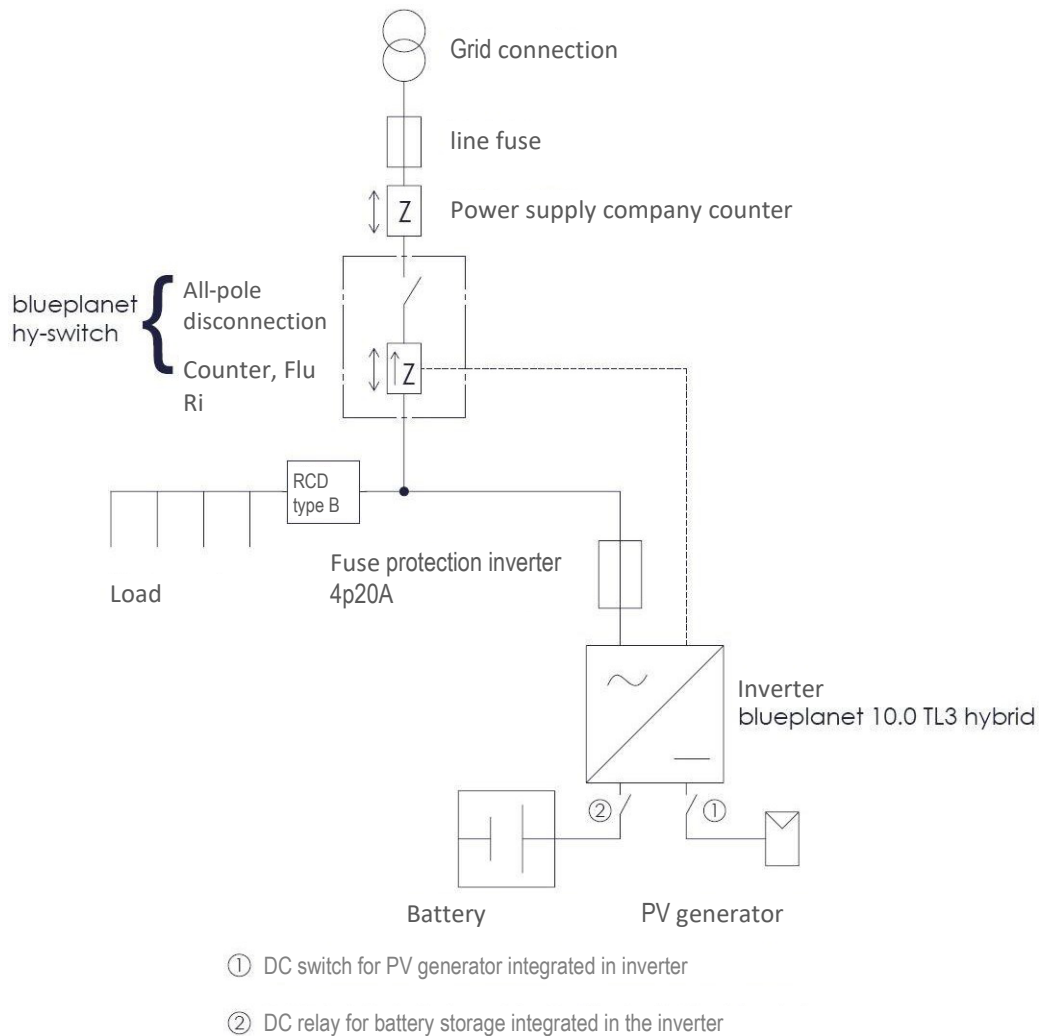

Fig. 1: Diagram of the system. For standalone systems, the path from the grid connection to the blueplanet hy-switch is omitted

Legend	Definition / information on the connection
PV generator	The PV generator converts the radiant energy of sunlight into electrical energy (direct current).
Inverter	The PV generator is connected to the device's DC connection.
Inverter fuse protection (line protection)	The circuit breaker is an overcurrent protection device.
Power supply company counter	The feed-in counter and reference counter are to be specified and installed by the power supply company. Some power supply companies also allow the installation of your own calibrated counters.
RCD type B	Residual current protective devices are mandatory when installed as standalone system or with backup current function
Battery	Excess power is stored in the battery storage unit until it is used again.

### 3.4 Compatible accessories

#### 3.4.1 KACO blueplanet hy-switch

KACO blueplanet hy-switch is used to record the power at the grid connection point or the installation string to be compensated by the device. This measured value is transmitted to the device via data communication between the device and KACO blueplanet hy-switch. This enables the integrated energy management system to adjust for the load to be compensated and to perform this adjustment very quickly. KACO blueplanet hy-switch is required for grid-parallel installations with a battery storage unit.

Features of KACO blueplanet hy-switch:

- Energy consumption recording for optimisation of self-consumption
- In the event of a power failure, all poles must be disconnected from the public power grid
- Integrated current sensors up to 50 A
- 3 x 3.5 mm jack connection for expandability with external current sensors up to 100 A
- RJ45 connector for communication between KACO blueplanet hy-switch and the device



Fig. 2: KACO blueplanet hy-switch

For further information, please refer to the KACO blueplanet hy-switch manual. The design of the communication port is described in chapter 7.6.

#### 3.4.2 Released battery storage units

The following battery storage units are included in the current version 7.x of the device software.

Tab. 1: Released battery storage units

Vendor	Type	Capacity (approx.)
BYD	Battery-Box H	5.1 bis 10.2 kWh
BYD	Battery-Box Premium HVS	5.1 bis 10.2 kWh
BYD	Battery-Box Premium HVM	8.3 bis 22.1 kWh
Energy Depot	DOMUS 2.5	5.0 bis 20.0 kWh
Energy Depot	DOMUS 3.6	7.2 bis 28.8 kWh

The current release list can be found in the download area of the KACO new energy homepage. General

information on connecting the battery storage unit to the device can be found in chapter 7.5.

Please consult the manual of the battery manufacturer.



## 4 Technical data

### 4.1 General data



Fig. 3: KACO blueplanet hybrid 10.0 TL3 inverter

#### Features of blueplanet hybrid 10.0 TL3

- 3-phase 10 kW hybrid inverter
- 2 integrated MPP trackers
- Fast load regulation (<100 ms)
- High efficiency: PV 
  - Grid = >98%
  - PV  Battery = >97% Battery 
  - Grid = >97%
- Pure sinusoidal output voltage
- Operation modes: Grid operation, compensation mode, standalone mode, standby power operation
- Aluminium housing
- Convection cooling
- All connections are plug-and-play

### 4.2 Detailed technical data

<b>PV input (DC)</b>		<b>Efficiency</b>	
Max. recommended PV generator power	15000 W	PV (DC) to grid (AC) [max.]	>98.1 %
Number of inputs / MPP tracker	2	PV (DC) to grid (AC) [EU]	>97.8%
Nom. / max. DC voltage	680 V DC / 900 V DC	PV (DC) to battery (DC) [max.]	>98.8 %
Switch-on voltage	DC 240 V	Battery (DC) to grid (AC) [max.]	>97.7 %
MPP range@rated power	420 V DC - 740 V DC	Night consumption (off)	<0.1 W
Working range	200 V DC - 850 V DC	Idle consumption	<20 W
max. input power per MPP Tracker	12 A		
Maximum short-circuit current I <sub>sc max</sub>	15 A per input		
Overload response	Operating point shift		
<b>Battery operation input (DC)</b>		<b>Battery operation AC connection</b>	
Nom. DC voltage	DC 425 V	Nominal charging power	9990 W
Max. charge and discharge current	25 A	Nominal discharge power	9990 W
Battery voltage Min. - Max.	96 V DC-450 V DC	Voltage waveform in standby current mode	true sine
Galvanic isolation	no	Number of phases	3
Protection	Fuse, cut-off relay		
<b>Grid supply (AC)</b>		<b>Efficiency</b>	
Nom. AC power	9 990 W	Grid frequency range	47.5 Hz-51.5 Hz
Max. AC power	11 000 VA	Power factor	0.9c-0.9i
Number of phases	3	Topology	Transformerless
Type. Power per phase on the grid	3 330 W	Load regulation	200 ms
Max. AC current per phase feed-in	16.1 A RMS	Power in standby mode (optional)	max. 4 000 W per phase and max. 10 000 W phase sum
	sym. / asym.		
Nom. AC voltage	210 - 264 V AC	Initial short-circuit alternating current (according to IEC 62109-2)	16.4 A
AC voltage range	184 - 264 V AC	Inrush current (according to IEC 62109-2)	1.7 A

General data			
Dimensions (WxHxD)	610 x 552 x 200 mm	Protection rating (IEC 60529)	IP20
Weight	37 kg	Housing	Aluminium
Display	LCD	Clock frequency	20 kHz
DC circuit breaker	Built-in	Grid parallel operation	grid-connected
RCD circuit breaker	integrated (type B)	Energy source for charging operation	PV, grid
NA protection	integrated (VDE AR-N 4105)	Degree of contamination	PD2
Battery cut-off relay	Built-in	Protection class (IEC 62109-1)	I
Operating temperature range	+5 to +40°C	DC Overvoltage category (IEC 60664-1)	II
Installation height*	0-2000 m	AC overvoltage category (IEC 60664-1)	III
Humidity	20 - 90% RH (non-condensing)	WEEE Reg. No.	DE57110363
Protection (backup power operation)	PE, RCD type B **	Certificates	VDE 0126, VDE AR-N 4105
Noise emission	<35 dB(A)	Warranty	5 years
Overtemperature behaviour	Regulation		

Connections	
DC connection for battery with automatic disconnect	PhoenixContact Sunclix
DC connection for PV	PhoenixContact Sunclix
AC connection	5-pole PhoenixContact - Art. 1409205
AC connection max. cable cross-section	4 mm <sup>2</sup>
Communication ports	2 x RJ45 (RS485), 1 x RJ45 (Ethernet) to external
Supported devices	
Energy storage ***	BYD Battery-Box HVS 5.1-10.2 and HVM 8.3-22.1, Energy Depot DOMUS 2.5
Measurement	blueplanet hy-switch

Energy conversion paths			
PV(DC) to grid (AC)	PV (DC) to battery (DC)	Grid (AC) to battery (DC)	Battery (DC) to grid (AC)
yes	yes	yes (with external EMS)	yes

\* Power reduction 2% per 100 m altitude above 1000 m  
 \*\* A separate residual current protective device (RCD type B) must be installed if two or more inverters are coupled together or if the standalone / grid backup operation is used.  
 \*\*\* Release list, see manual

Additional technical data according to IEC 62109-2

<b>Input levels</b>	Max. input source feedback current	0
<b>Output levels</b>	Initial short-circuit alternating current (I <sub>k</sub> " first single period effective value)	16.4 A
	Inrush current	1.7 A

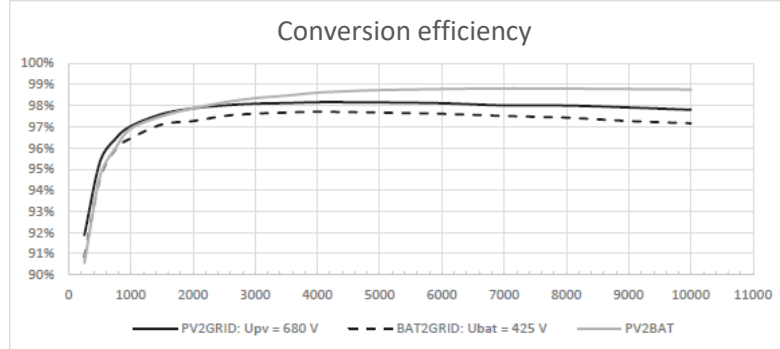

4.3 Environmental data

Table 1: Environmental data

<b>Installation height</b>	<2,000 m
<b>Ambient temperature</b>	+5°C + 40°C
<b>Protection rating (KACO installation location)</b>	IP20
<b>Humidity range (non-condensing) [%]</b>	20 - 90

## 5 Transportation and Delivery

Every product leaves our factory in perfect electrical and mechanical condition. Special packaging ensures that the devices are transported safely. The shipping company is responsible for any transport damage that occurs.

### 5.1 Scope of delivery

The following parts and components are supplied with the device:



Inverter



3 pairs of DC connectors  
(SUNCLIX connectors)



1 x AC connector (Phoenix  
Contact PRC 5-FC-FS6 12-1)



2 x countersunk screw  
M4x20 mm (already pre-  
assembled)



Wall bracket (already  
pre-assembled)



Manual

### Check the equipment included

1. Carefully inspect the device for transport damage; check the scope of supply.
2. Immediately notify the shipping company in case of the following:
  - Damage to the packaging that indicates that the device may have been damaged.
  - Obvious damage to the device.
3. Send a damage report to the shipping company immediately.
4. The damage report must be received by the shipping company in writing within 6 days following receipt of the device. We will be glad to help you if necessary.

### 5.2 Transporting the device



#### CAUTION

##### Risk of injury caused by excessive physical strain

Lifting the device, for transport, relocation and assembly, can result in injuries (e.g. back injuries).

- › The device must be transported and installed by at least 2 persons.

## CAUTION

### Hazard due to impact; risk of breakage to the device!

Faulty storage can form condensate in the device and impair the device functioning (e.g. storage outside the ambient conditions or temporary relocation from a cold to a hot environment).

- › › Pack the device securely for transport.
- › Transport the device using the intended carrying handles of the packaging box.
- › Do not expose the device to any shocks.

Packaging:	Folding cardboard box
Packaging size:	720 x 685 x 320 mm
Total weight incl. packaging:	40Kg

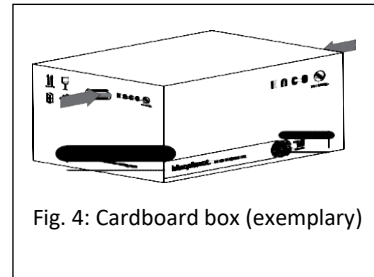

## 5.3 Installation tool

The codes given in the table below are used in all usage instructions for assembly/installation/maintenance and disassembly for the tools and tightening torques being used.

Tab. 2: Key and description of tool codes

Code (s)	Shape of the connector
✕W	External hexagon
✕A	Internal hexagon
✕D	Torx
✕S	Slot

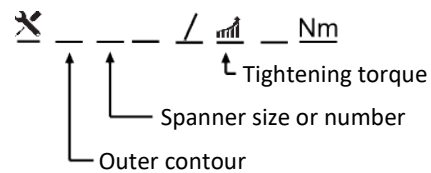

## 6 Assembly and preparation



### CAUTION

#### Risk of injury caused by excessive physical strain

Lifting the device, for transport, relocation and assembly, can result in injuries (e.g. back injuries).

- › The device must be transported and installed by at least 2 persons.

### 6.1 Required material

#### Solar cable

For the connection of the PV generator to the device. It can also be used to connect the battery; refer to the battery manufacturer's manual.

- Only designated solar cables are permitted, either type PV1-F or UL-certified solar cables (ZKLA), AWG 10-14.

Table 2: Technical requirements for solar cables

Technical data according to standard	EN 50521	UL 6703
Ambient temperature	-40°C...+85°C	-40°C...+70°C
Max. nominal voltage	1100 VDC	600 VDC
Max. nominal current	2.5 mm <sup>2</sup> - 27 A; 4.0 mm <sup>2</sup> - 40 A; 6.0 mm <sup>2</sup> - 40 A	AWG 14 - 15 A; AWG 12 - 20 A; AWG 10 - 30 A
Cable diameter	5 ... 8 mm	5 ... 8 mm

### NOTE



#### Observe the manufacturer's instructions of the manufacturer of the connector.

To use the provided SUNCLIX connectors, use only solar cables with a nominal cross section between 2.5 mm<sup>2</sup> and 6 mm<sup>2</sup>.

- › Please observe the information on nominal voltage and nominal current.
- › Protect the connectors from moisture and dirt.

#### Connection cable for the battery storage

If specific connection cables have been supplied by the battery manufacturer, these cables must be used. To be on the safe side, make sure that SUNCLIX connectors are installed on the side of the device.

#### Communication cable

Patch cable for communication with KACO blueplanet hy-switch, the battery and the Internet. An RJ45 connector must be fitted on the device side. The cable must comply with CAT 5E S/FTP. The length depends on the installation location, but should not exceed 20m. Cross-over assignments cannot be used.

#### Wall bracket fixing materials

- 4x fixings
- 4x fixing screw min. Ø6mm, minimum length 40mm
- 4x plain washer matching the screw, outer Ø max. 20mm



## 6.2 Choosing the installation location

### DANGER



#### **Risk of fatal injury due to fire or explosions!**

Fire caused by flammable or explosive materials in the vicinity of the device can lead to serious injuries.

- › Do not mount the inverter in potentially explosive atmospheres or in the vicinity of highly flammable materials.

### CAUTION

#### **Property damage due to gases that have an abrasive effect on surfaces when they come into contact with ambient humidity caused by weather conditions.**

The device housing can be seriously damaged due to gases in combination with air humidity resulting from weather conditions (e.g. ammonia, sulphur).

- › If the device is exposed to gases, the installation must be carried out at observable locations.
- › Perform regular visual inspections.
- › Immediately remove any moisture from the housing.
- › Ensure adequate ventilation at the installation location.
- › Immediately remove dirt, especially on vents.
- › Failure to observe these warnings may lead to device damage which is not covered by the manufacturer warranty.

### NOTE



#### **Access by maintenance personnel for service**

Any additional costs arising from unfavourable structural or mounting conditions shall be billed to the customer.

### Requirements for the installation space

- As dry as possible, climate-controlled, the waste heat must be able to be dissipated away from the device.
- Unobstructed air circulation.
- Observe ambient temperatures according to the data sheet.
- Observe minimum distances to the sides of the housing, see Fig. 7
- Accessible from the front and sides without requiring additional resources.
- At a height at which the display can be read at any time.
- Do not install outdoors; the device is designed for indoor use only (IP20).

### Requirements on the installation surface

- Must have adequate load-bearing capacity
- Must be accessible for installation and maintenance
- Must be made of heat-resistant material (up to 90 °C)
- Must be flame resistant

## 6.3 Unpacking the device

### CAUTION

#### Property damage as a result of condensation

Faulty storage can form condensate in the device and impair the device functioning (e.g. storage outside the ambient conditions or temporary relocation from a cold to a hot environment).

- › Prior to installation, check the inner area for condensation and if necessary, allow it to dry sufficiently before installation.

### Unpacking the device

1. Loosen packaging tape from cardboard box.
2. Open the carton at the top. Be careful not to damage the device when using sharp objects.
3. Remove installation material and documentation.
4. Reach through the housing and slide the device out of the carton.
5. Remove the protective packaging from the housing.
6. Remove the wall bracket from the back of the device by loosening and removing the locking screws according to Fig. 6 [~~X~~T\_TX20/  1.5Nm].

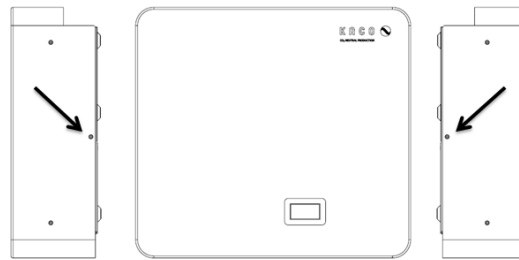

Fig. 6: Position of the locking screws

## 6.4 Securing the wall bracket

### CAUTION



#### Hazard when using unsuitable fixing materials!

If unsuitable fixing materials are used, the device could fall and persons in front of the device may be seriously injured.

- › Use only fixing materials that are suitable for the mounting base.
- › Only install the devices upright and side by side.

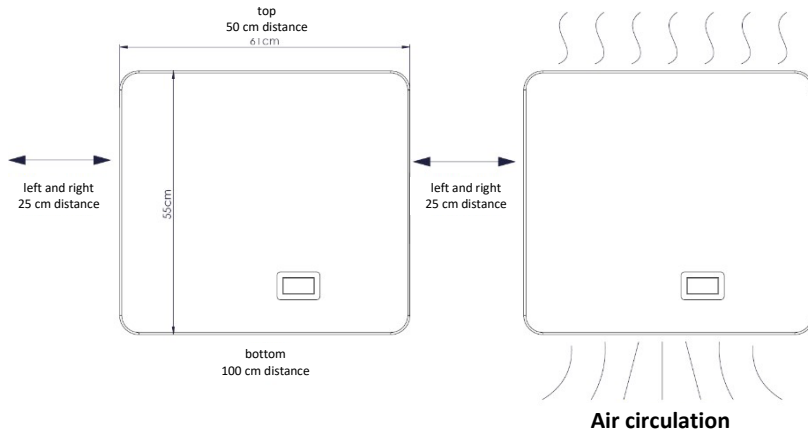

Fig. 7: Minimum distances around the device

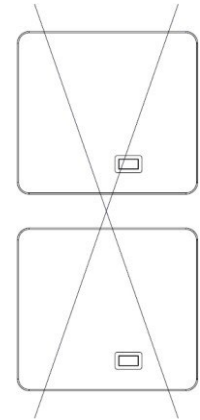

Fig. 8: Prohibited mounting position

## NOTE



### Side distance

The minimum side distance corresponds both to the distance to structural elements and to the total distance between two devices.

## NOTE



### Do not mount two devices one above the other!

The devices may only be mounted side by side. When mounted one above the other, the warm air escaping from the lower device can impair the function of the upper device.

The appropriate screw connection (fixings and screws) is selected and provided by the installer, taking the wall thickness and material into consideration. The wall bracket must be firmly screwed to the wall with the four suitable screws.

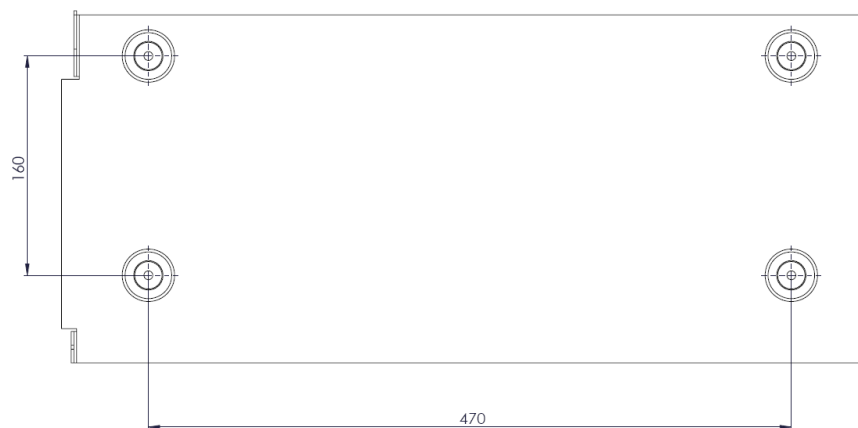

Fig. 9: Drill hole dimensions

## Procedure for mounting the wall bracket

- ⌚ The wall bracket must be removed from the back of the device. (cable ties)
- 1. Remove the wall bracket from the device.
- 2. Determine the mounting position of the device. Check compliance with minimum distances (Fig. 7).
- 3. Hold the wall bracket horizontally in position as a template.
- 4. Mark the position of the drill holes using the recess in the wall bracket, or mark them according to the dimensions in Fig. 9.
- 5. Determine the size of the drill holes according to the fixing material and drill holes.
- 6. Fix the wall bracket to the wall with suitable fixing material (see 6.1).
- 7. Check the wall bracket for a firm seat.

## 6.5 Installing and securing the device

### CAUTION



#### Risk of injury from improper lifting and transport

If the device is lifted improperly, it can tilt and result in a fall.

- › Always lift the device vertically.
- › Use a climbing aid for the chosen installation height.
- › Wear protective gloves and safety shoes when lifting and lowering the device.

### NOTE



#### Power reduction due to heat accumulation!

If the recommended minimum clearances are not observed, the device may reduce the power due to insufficient ventilation and the resulting heat build-up.

- › Observe minimum clearances and provide for sufficient heat dissipation.
- › All objects on the device housing must be removed during operation.
- › Ensure that no foreign bodies prevent heat dissipation following device installation.

## Lifting and installing the device

- ⌚ The mount has been installed.
- 1. The device is tilted slightly to the rear. Both hooks of the wall bracket must engage into the bolts of the outer cooling fins. When inserting, make sure that the hooks are not bent. When the bolts are hooked into the wall bracket, the device is carefully tilted down until it is parallel to the wall.

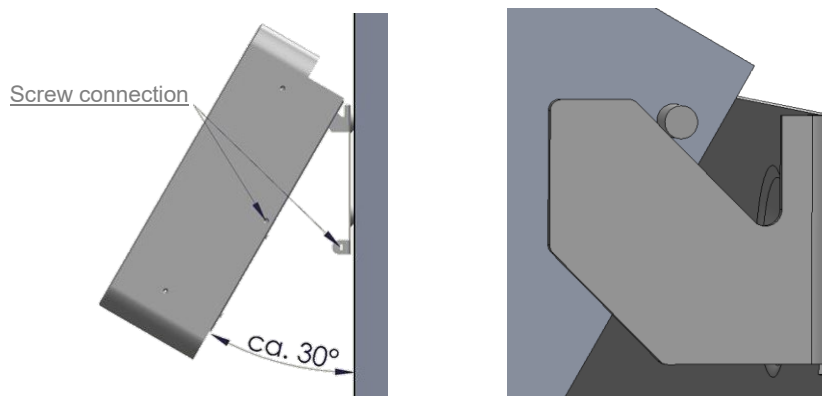

Fig. 10: Installation

## CAUTION

### Avoid damage due to hard striking!

Hard hitting or an uneven surface can damage the device, especially the heat sink.

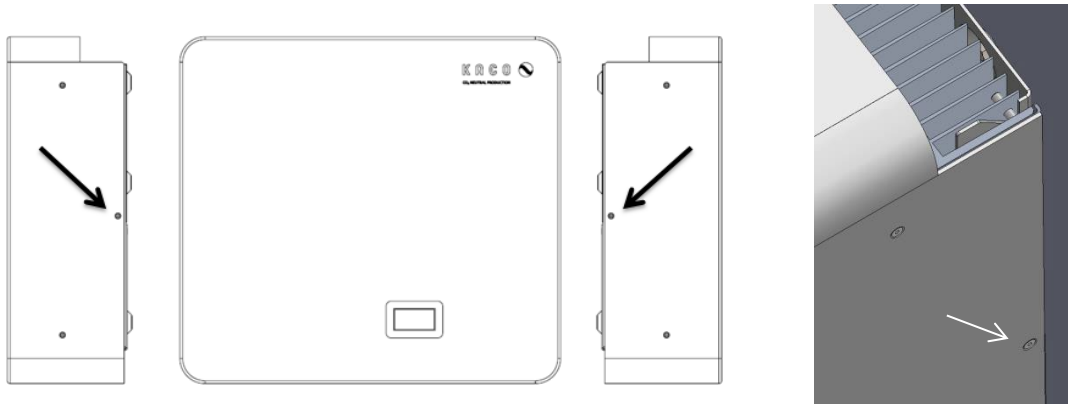

Fig. 11: Position of the safety screws (on left and right side)

2. After attaching the device to the wall bracket, screw in the counter-sun [ $\times$  T<sub>TX20</sub>/mm] 1.5 Nm] for fixing. Make sure that the bottom of the housing cannot be moved forward.

» The device is successfully installed.

## CAUTION



### Safety catch

The safety screws are used to prevent the device from being accidentally unhooked.

- › This screw connection may only be removed for disassembly!

## 7 Installation

### 7.1 General information

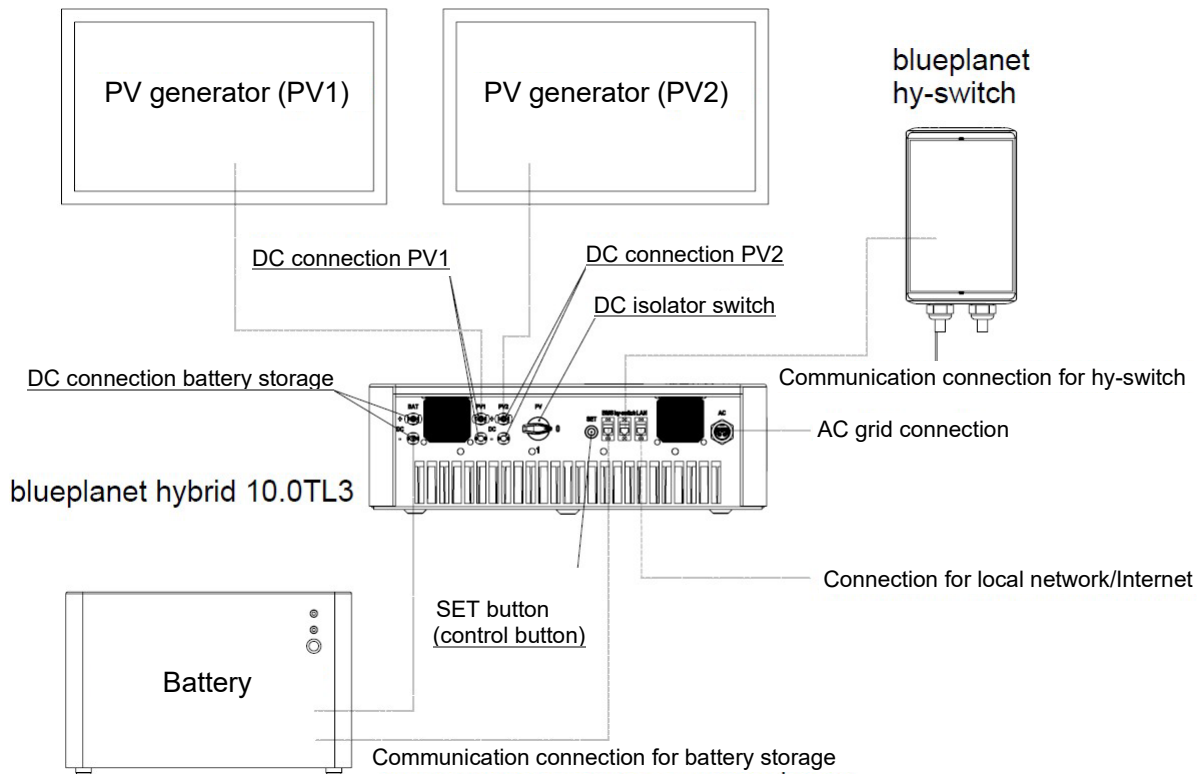

Fig. 12: Overview of connections

## DANGER

**Lethal voltages are still present in the connections and cables even after the device has been switched off and disconnected!**

Severe injuries and/or death may occur if the cables and terminals are touched.



- › **Do not open the device.** All connections are externally accessible.
- › The device must be mounted in a fixed position before being connected electrically.
- › Comply with all safety regulations and current technical connection specifications of the responsible power supply company.
- › The device is only permitted to be installed by an authorised electrician.
- › Switch off the grid voltage by turning off the external circuit breakers.
- › Terminate DC circuits.
- › Switching off the inverter alone does not protect against electric shock.
- › Check that all AC and DC cables are completely free of current using a clip-on ammeter.

**WARNING**



**Arc event**

An arc event can cause serious injury if plug connections, especially the DC connectors, are disconnected under load.

Never disconnect a connector from a live cable during operation!

**WARNING**



**To prevent the risk of fire**

Never cover the device completely or partially when it is in operation.





**NOTE**

**Opening of the device**

No opening is required for installation, maintenance or deinstallation. Opening the housing cover will invalidate your warranty.

**Required tools:**

- Screwdriver  [XS\_3.5]
- Open-end spanner  [XW\_30]
- Open-end spanner  [XW\_15]

**7.2 Information regarding electrical connections**



**WARNING**



**Risk of fire or electric shock**

To avoid the risk of fire or electric shock, make sure that the cabling is in good condition and not undersized.

- › Never install defective or inferior cables.
- › Cable connections may only be connected or disconnected to a switched-off device. Please note 10.1.



**NOTE**

**Select conductor cross-section, safety type and safety value in accordance with the following basic conditions:**

Country-specific installation standards; power rating of the device; cable length; type of cable installation; local temperature

### 7.3 Connecting the device to the power grid

 **Authorised electrician**

#### WARNING



**Possible risk of fatal electric shock**

This device may cause a current with a DC component. If additional residual current devices (RCD) and residual current monitors (RCM) are used to protect against direct or indirect contact, only RCD or RCM type B are permitted on the supply side of this product.



#### NOTE

**AC-side disconnection unit**

- › An AC-side disconnection unit must be provided during the final installation stage.
- › This disconnector mechanism must be installed so that it can be accessed at any time without obstruction.
- › The grid connection leads (AC) must be protected with a four-pole circuit breaker type B 20A.



#### NOTE

When the line resistance is high, i.e. long cables on the grid side, the voltage at the grid terminals of the device will increase in feed-in mode. If the voltage exceeds the country-specific grid overvoltage limit value, the device switches off.

- › Ensure that the cable cross-sections are sufficiently large or that the cable lengths are sufficiently short.
- › Ensure proper strain relief of the connecting cables.



#### NOTE

Make sure that the device is compatible with the installation environment:

- Is the type of grid suitable for the installation?
- Is the grounding implemented correctly?
- Are grid voltage and grid frequency within specification?

Tab. 2 Connect the device to the power grid

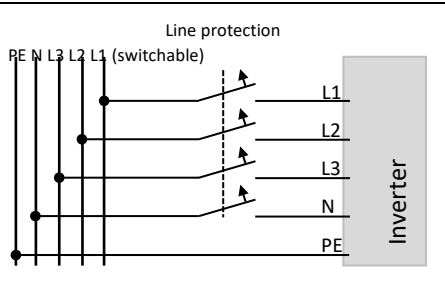
Model	blueplanet hybrid 10.0 TL3	
Nominal grid voltage	230/240 VAC	
Line cross-section (mm <sup>2</sup> )	≥2.5	
AWG	14	
Recommended cable:	H05RR-F 5G2,5	



### 7.3.1 Connecting the device to a standalone grid

 **Authorised**

#### WARNING



**Possible risk of fatal electric shock**

This device may cause a current with a DC component. In standalone mode, an additional residual current device (RCD) or a residual current monitor (RCM) of type B must be used on the supply side for protection against direct or indirect contact.

#### WARNING



**Possible risk of fatal electric shock**

The connection N and PE must be made directly at the plug of the device or in the distributor so that the external RCD type B can correctly detect the residual currents.

#### WARNING



**Possible risk of fatal electric shock**

Do not activate islanding if the connected grid is being serviced or has defects.

#### CAUTION

Transient voltage peaks can occur during rapid load changes in the standalone grid. Connected devices must be able to withstand transients of up to 450 V or be protected against them accordingly.



#### NOTE

Standalone mode is a separate operation without a public grid. Note that:

- No hy-switch is required on the device.
- Standalone mode requires the installation of a function extension certificate.
- Islanding requires a voltage to be applied to the PV connections. Operation and cold start without PV voltage applied is not possible.
- No other external supplies may be connected in the standalone grid.
- Unsuitable loads can cause the inverter to shut down.
- Island network formation is only activated by manual intervention directly on the device or in the hy-sys software. After a fault-related switch-off, the device must also be switched on again manually.
- Password protection against activation by unauthorised persons can be activated in hy-sys.



**NOTE**

**AC-side disconnection unit**

- › An AC-side disconnection unit must be provided during the final installation stage.
- › This disconnector mechanism must be installed so that it can be accessed at any time without obstruction.
- › The grid connection leads (AC) must be protected with a four-pole circuit breaker type B 20A.

Tab. 3 Connecting the device to a standalone grid

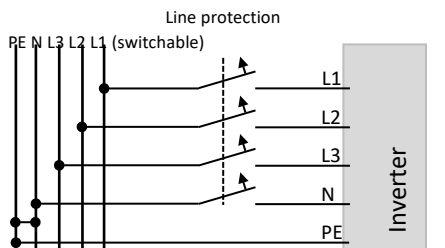
Nominal voltage	230 V AC	
line frequency	Adjustable 45 to 65 Hz	
Maximum power three-phase	9.99 kW	
Maximum power single-phase	4.0 kW	

**7.3.2 Connecting the device for standby power operation**

 **Authorised electrician**

**WARNING**



**Possible risk of fatal electric shock**

This device may cause a current with a DC component. In standalone mode, an additional residual current device (RCD) or a residual current monitor (RCM) of type B must be used on the supply side for protection against direct or indirect contact.

**WARNING**



**Possible risk of fatal electric shock**

There must be no connection N and PE in the standby circuit. This is done by the hy-switch when switching to standby power operation.

When installing the unit and the hy-switch, check the standby power circuit accordingly.

**WARNING**



**Possible risk of fatal electric shock**

Do not activate standby current generation if the connected grid is being serviced or has defects.

**CAUTION**

Transient voltage peaks can occur during rapid load changes in the standby power grid. Connected devices must be able to withstand transients of up to 450 V or be protected against them accordingly.



## NOTE

Standby power is a separate operation with connection to the public grid. In the event of a grid failure, the connection to the supply grid is disconnected and a temporary standalone grid is established. Note that:

- A hy-switch must be connected to the device. The use of external current sensors is not possible.
- Standby power operation requires the installation of a function extension certificate.
- Standby power operation requires voltage to be applied to the PV connections. Operation and cold start without PV voltage applied is not possible.
- Unsuitable loads can cause the inverter to shut down.
- The device can be configured for automatic or manual start of the standby power supply. If the automatic start has not occurred after 3 minutes, the standby power supply must be started manually.
- After an overload of the device, the standby power operation is deactivated for 90 seconds. Subsequently, the standby power operation can be started again automatically or manually.
- Password protection against activation by unauthorised persons can be activated in hy-sys.



## NOTE

If there are other inverters in the standby power circuit, all inverters must be configured accordingly. The necessary steps can be found in the respective manuals.

- The power of the additional inverters is compensated by the device in grid-connected operation as far as possible.
- In the event of a grid failure and setting up a standby power grid, the other inverters must remain separate. The grid frequency is therefore 52 Hz.



## NOTE

### AC-side disconnection unit

- › An AC-side disconnection unit must be provided during the final installation stage.
- › This disconnector mechanism must be installed so that it can be accessed at any time without obstruction.
- › The grid connection leads (AC) must be protected with a four-pole circuit breaker type B 20A.

### 7.3.3 Permissible connectors



#### Authorised electrician

Only the Phoenix Contact AC connector PRC 5-FC-FS6 12-1 may be used.

## CAUTION



### Bending radii of the cables

Observe the permissible bending radii during installation, as the protection rating is endangered by excessive bending forces (Fig.19: Connecting the connector Fig. 20: Minimum bending radius ). Intercept mechanical loads upstream of the connector (e.g. with cable ties).

## CAUTION

Only use the original PRC 5-FC-FS6 connector from Phoenix Contact to connect to the PRC 5-FT25-MC device connector.



## NOTE

Use a 5-pin cable with the diameter stated/suitable in the table and with wires with a cross-section of 2.5 ...6 mm<sup>2</sup>. The cable diameter must lie between 12 and 16 mm.

- › Ensure that the cable cross-sections are sufficiently large or that the cable lengths are sufficiently short.
- › Ensure proper strain relief of the connecting cables.

### 7.3.4 AC cable fitting assembly



Description of the individual parts of the AC connector (Fig. 13: AC connector)

1. Cable fitting
2. Seal
3. Housing
4. Contact carrier

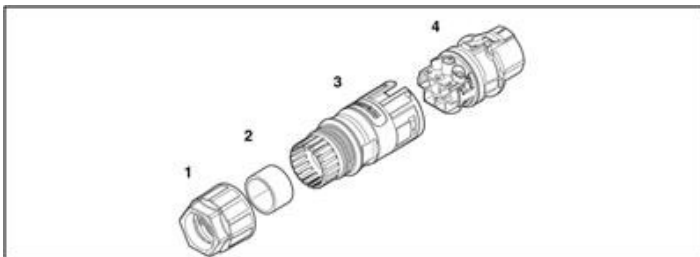

Fig. 13: AC connector

Preparation for mounting the connector according to Fig. 14

1. Slide the cable fitting over the cable.
2. **Only for 1410656:** Choose a seal that fits your cable diameter.
3. Slide the housing with the seal over the cable.
4. Strip the cable by 50 mm.
5. Then shorten wires N and L1, L2, L3 by 8 mm.
6. Strip the wires by 12 mm.
7. With flexible wires, we recommend the use of wire sleeves conforming to DIN 46228 that are pressed together using crimping pliers CRIMPFOX 6 (1212034).

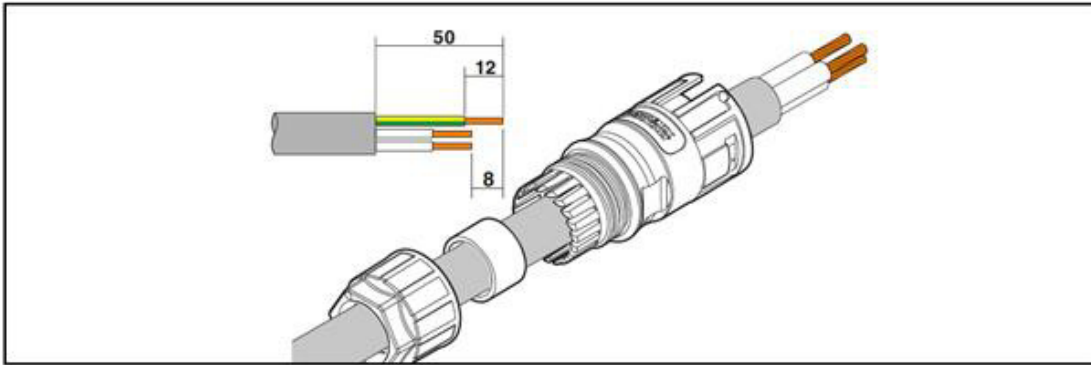

Fig. 14: Cable stripping dimensions

#### Connecting wires •

- Connect the wires to the contact carrier (Fig. 15).
- The assignment depends on the marking on the contact carrier.
- Tighten the screws on the contact carrier to 1 Nm (Placing the wires Fig. 16).
- Push the contact carrier into the housing until it audibly engages (Fig. 17).
- Tighten the cable fitting with an open-end spanner  $\times W_{30}$   $\uparrow$  6.5 Nm (Interconnection Fig. 18).

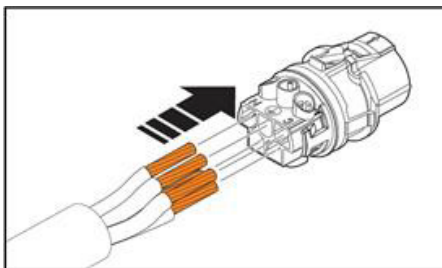

Fig. 15: Placing the wires

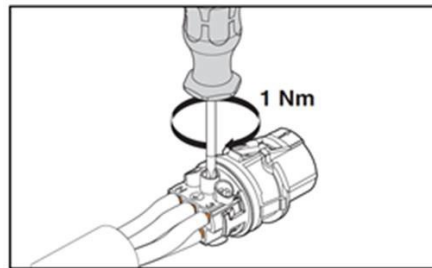

Fig. 16: Tightening the wires

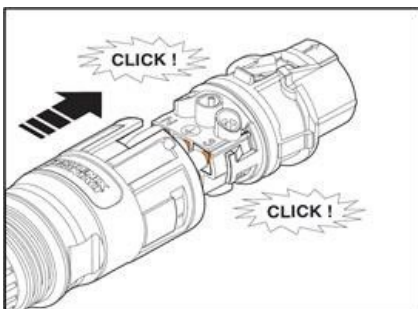

Fig. 17: Interconnection

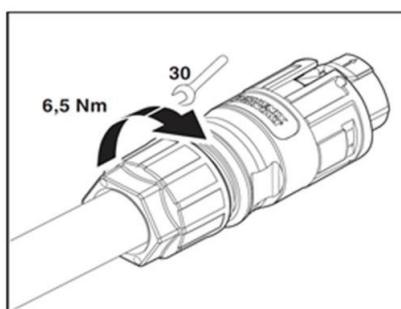

Fig. 18: Tightening the cable fitting

### 7.3.5 Connecting the connector



Latch the assembled connector with the device connector (Fig. 19: Connecting the connectors).  
Observe the required minimum bending radii when laying the cable (Fig. 20: Minimum bending radius).

## CAUTION

### Plug in or disconnect connectors

Never connect or disconnect the connectors under load. The connectors are not suitable for disconnecting the power.

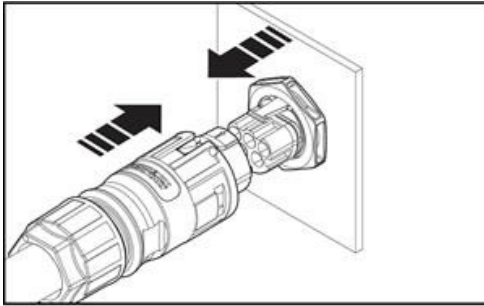

Fig. 19: Connecting the connectors

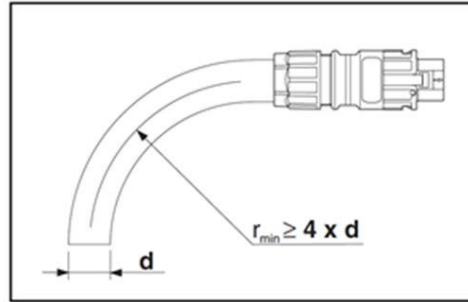
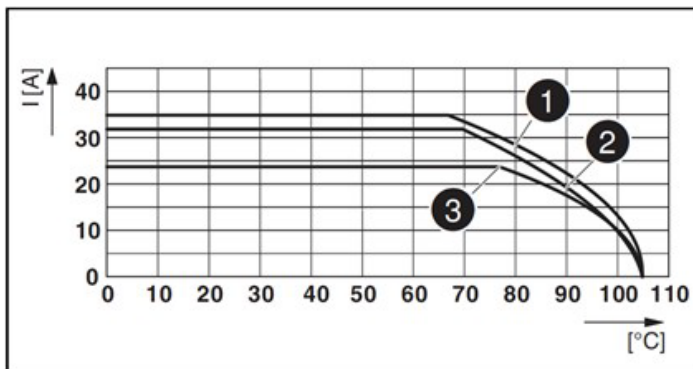

Fig. 20: Minimum bending radius

### 7.3.6 Technical data

Protection rating	IP65/IP68 (2 m, 24 h)
Nominal current	35 A (observe the derating and the cable cross-section)
Nominal voltage	690 V
Operating temperature	-40°C ... 100°C
Material	PPE

The following figure shows the dependence of the nominal current [A] on the ambient temperature [°C] depending on the cable cross-section:



- 6 mm<sup>2</sup> (max. 35 A) ❶
- 4 mm<sup>2</sup> (max. 32 A) ❷
- 2.5 mm<sup>2</sup> (max. 24 A) ❸

Fig. 21: Maximum currents and derating according to cable cross-sections used.

## 7.4 Connect PV generator to device

### 7.4.1 Designing the PV generator



The maximum generator power (at STC conditions) per input (MPP tracker) must not exceed 6 kW.

#### CAUTION

##### Damage to components due to faulty configuration

In the expected temperature range of the PV generator, the values for the no-load-voltage and the short circuit current must never exceed the values for  $U_{dcmax}$  and  $I_{scmax}$  in accordance with the technical data.

- › Observe limit values in accordance with the technical data.



#### CAUTION

##### Grounding the PV system

To ensure proper installation of the PV generator, the PV module frames and mounting frames in particular must be grounded.

- › The PV modules themselves (positive or negative pole) must not be earthed!

#### NOTE



##### Type and configuration of the PV modules

Connected PV modules must be dimensioned for the DC system voltage in accordance with IEC 61730 Class A, as well as for the value of the AC grid voltage.

It is a transformerless inverter. It can be operated with mono- or polycrystalline PV modules. If you wish to operate thin-film modules together with the hybrid inverter, please contact the module manufacturer beforehand to ensure the compatibility of the entire system.

Recommended standard connection

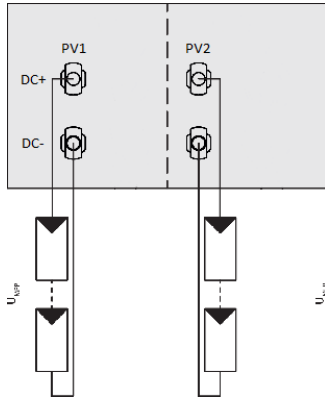

Fig. 22: Recommended standard wiring and assignment of both MPP trackers.

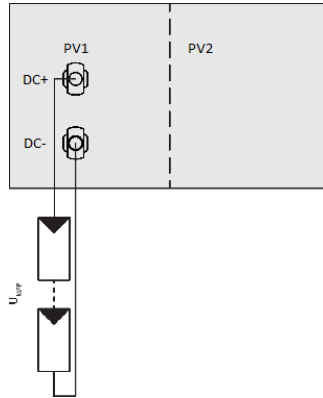

Fig. 23: Assignment of only one MPP tracker.

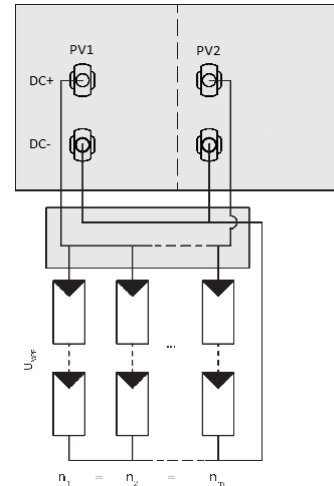

Fig. 24: Parallel input circuit for one or more module strings.

Possible wiring variants

1 PV generator each on one MPP tracker

The MPP voltages of the two DC strings can be different. They are supplied by separate, independently operating MPP trackers (MPP trackers PV1 and PV2).

The number of modules per MPP tracker is arbitrary as long as the power, current and voltage limits are observed.

The maximum power per input according to the technical data must be observed (see 4.2).

$I_{max}$ : Amperage per tracker < max. input current per MPP tracker (see 4.2).

1 PV generator for one tracker. The second tracker is deactivated

The MPP voltage must be within the specifications. A voltage is induced at the unassigned PV input, which is displayed on the inverter during the start process. This behaviour can be avoided by short circuiting the unassigned PV input.

The number of modules per MPP tracker is arbitrary as long as the power, current and voltage limits are observed.

The maximum power per input according to the technical data must be observed (see 4.2).

$I_{max}$ : Amperage per tracker < max. input current per MPP tracker (see 4.2).

1 PV generator parallel on both MPP trackers

The DC inputs can also be connected in parallel. The maximum permissible nominal current (DC) is doubled. In this way, it is possible to connect several strings in parallel. They must have the same voltage. ( $U_{n1}=U_{n2}=U_{nm}$ ).

The number of modules per string must be identical:  $n1=n2=nm$   
The power, current and voltage limits must be observed.

The double maximum power per input according to the technical data must be observed (see 4.2).

$I_{max}$ : Amperage < the double max. input current per MPP tracker (see 4.2).



## 7.4.2 Configuring the DC connector

 **Authorised electrician**

The number of DC connectors to be configured depends on the number of strings used. At least two DC connectors must be configured. Please proceed as follows for each DC connector:

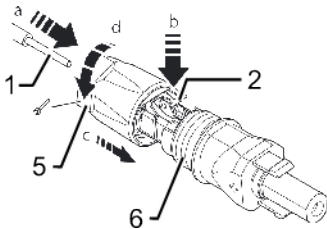

Fig. 25: Insert wires

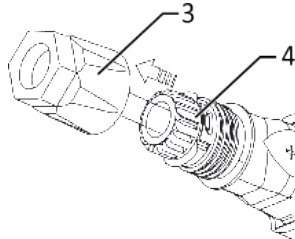

Fig. 26: Slide insert into sleeve

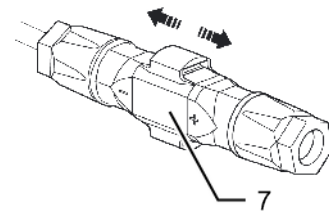

Fig. 27: Check fastening

### Legend

1	Wire for DC connection	5	Cable fitting
2	Spring	6	Contact plug
3	Insert	7	Coupling
4	Sleeve		

 **DANGER**

**Lethal voltages are present in the DC cables**

Severe injuries and/or death may occur if the cables and terminals are touched.



- › The installation may only be carried out by a recognised electrician.
- › DC voltages of up to 900 V are possible.
- › Check that there is no current in any of the DC cables using a clip-on ammeter.
- › Photovoltaic modules supply a DC voltage as soon as they are exposed to light!

 Stripped and voltage-free solar cables

Whilst stripping wires, ensure that you do not cut any individual wires.

1. Insert isolated wires with twisted ends carefully up to the end stop.

**Wire ends must be visible in the spring.**

2. Close the spring so that the spring latches.
3. Slide insert into sleeve.
4. Secure and tighten the cable fitting [~~X~~W\_15/  1.8 Nm]
5. Join insert with contact plug.
6. Check latch by lightly pulling on the coupling.

› DC connector configured.

### NOTE



**The permissible bending radius of at least 4x the cable diameter should be observed during installation. Excessive bending forces endanger the protection rating.**

- › All mechanical loads must be absorbed in front of the plug connection.
- › Rigid adaptations are not permitted on DC plug connectors.

### 7.4.3 Checking the PV generator for a ground fault



#### DANGER



**Risk of fatal injury due to electric shock!**

Severe injury or death will result if the live connections are touched. When there is sunlight present on the PV generator, there is DC voltage on the open ends of the DC cables.

- › Only touch the PV generator cables on the insulation. Do not touch the exposed ends of the cables.
- › Avoid short circuits.
- › Do not connect any strings with a ground fault to the device.

### 7.4.4 Connecting the PV generator



#### DANGER



**Risk of fatal injury due to electric shock!**

Severe injury or death will result if the live connections are touched. When there is sunlight present on the PV generator, there is DC voltage on the open ends of the DC cables.

- › Only touch the PV generator cables on the insulation. Do not touch the exposed ends of the cables.
- › Avoid short circuits.
- › Do not connect any strings with a ground fault to the device.

#### CAUTION

**Damage to the PV generator in case of faulty configuration of the DC connector.**

A faulty configuration of the DC connector (polarity +/-) causes equipment damage in the DC connection if it is connected permanently.

- › Please check polarity (+/-) of the DC connector before connecting the DC generator.
- › Before using the solar modules, check the vendor's calculated voltage values against those actually measured. The DC voltage of the PV system must not exceed the maximum no-load voltage at any time.

#### CAUTION

**An incorrect connection of the PV generator can damage the device.**

Do not confuse the inputs for the PV generator with the battery input. Incorrect connection can damage the PV input or even the battery input.

- › The battery input can be damaged by the high PV voltage.
- › The PV input can be damaged by the high battery current.

## Connecting the PV generator

- ⌚ DC plug connector configured and PV generator checked to ensure there is no ground fault.
- ⌚ Device is switched off
- 1. Connect the DC plug connectors to the DC positive and DC negative connectors in pairs. The connections are marked with PV1 and PV2.

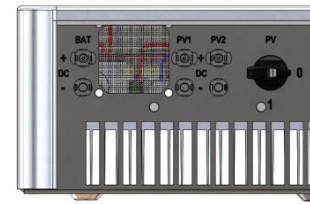

Fig. 28: Connections PV1 and PV2

» The PV generator is connected to the device.

## 7.5 Connecting the battery storage unit to the device

### 7.5.1 Checking the battery storage unit

 **Authorised electrician**

#### DANGER

**Risk of fatal injury due to electric shock, fire or explosions!**

Serious injury or death due to the use of unsuitable, not intrinsically safe or defective battery storage units!



- › Check the certification and release of the battery storage unit.
- › Check the battery storage unit for obvious damage.
- › Observe the manual of the battery manufacturer.

#### CAUTION

**Damage to the battery storage unit or the device due to the use of incorrect batteries**

Only released battery storage units may be connected. Please refer to our release list under 3.4.2 and the battery manufacturer's manual.

#### NOTE



**Check the earthing of the battery storage!**

Check that the battery storage unit is properly grounded according to the manufacturer's instructions. It must be connected to the same ground potential as the device itself.

## 7.5.2 Configuring the DC connector

 **Authorised electrician**

### DANGER

#### Risk of fatal injury due to electric shock!



Severe injury or death will result if the live connections are touched.

A high DC voltage can be applied to the battery storage unit at the open ends of the DC lines.

- › Only touch the battery storage unit cables on the insulation. Do not touch the exposed ends of the cables.
- › Avoid short circuits. This can lead to destruction of the battery.

### CAUTION

#### Damage to the battery storage unit in case of faulty configuration of the DC connector.

A faulty configuration of the DC connector (polarity +/-) causes equipment damage in the DC connection if it is connected permanently.

- › Please check polarity (+/-) of the DC connector before connecting the battery storage unit.

The connectors of the battery storage unit are configured according to the instructions for the PV generator; see 7.4.2.

## 7.5.3 Connecting the battery storage unit

 **Authorised electrician**

### CAUTION

#### An incorrect connection of the battery can damage the device.

Do not confuse the battery input with the inputs of the PV generator. Incorrect connection can damage the PV input or even the battery input.

- › The battery input can be damaged by the high PV voltage.
- › The PV input can be damaged by the high battery current.

↻ The connectors of the battery storage unit are configured.

↻ Device is switched off

## Connecting the battery storage unit

### DC plug connector

1. Connect the DC connectors to the DC positive and DC negative connectors in pairs. The connection is marked as BAT.
- » The device is connected to the battery storage unit on the DC side.

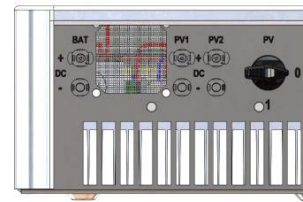

Fig. 29: BAT connection (DC)

### Communication cable

1. The communication cable of the battery is connected to the device. The communication cable must have an RJ45 connector. It must be connected to the BMS connection of the three communication ports on the bottom of the device.
- » The device is communicatively connected to the battery storage unit.

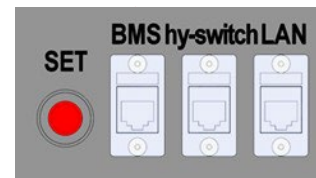

Fig. 30: BMS communication connection

## 7.6 Connecting KACO blueplanet hy-switch to the device



KACO blueplanet hy-switch is required for the adjustment and disconnection of the grid connection or the installation string to be compensated. This component is not required for installations without access to the public power grid.

### DANGER

**Improper installation of KACO blueplanet hy-switch allows components and cables to come into contact with life-threatening voltages**



Severe injuries and/or death may occur if the cables and terminals are touched.

- › Observe the KACO blueplanet hy-switch manual.
- › The device must be mounted in a fixed position before being connected electrically.
- › The device is only permitted to be installed by an authorised electrician.
- › Switch off the grid voltage by turning off the external circuit breakers.
- › Check that all AC and DC cables are completely free of current using a clip-on ammeter.

⌚ KACO blueplanet hy-switch must be installed according to the enclosed manual.

### Connecting KACO blueplanet hy-switch

1. Connect the communication cable of KACO blueplanet hy-switch to the device. The communication cable must have an RJ45 connector on both sides. A shielding of the communication cable between the blueplanet hybrid 10.0 TL3 and the blueplanet hy-switch must be interrupted on the blueplanet hy-switch side. Preferably, an RJ-45 plug without connection to the shielding on the hy-switch side should be used for this purpose. It must be connected to the hy-switch centre connection of the three communication ports on the bottom of the device.
- » The device is connected to KACO blueplanet hy-switch.

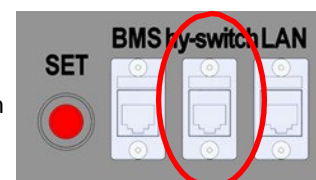

Fig. 31: Connecting the KACO blueplanet hy-switch communication

## NOTE

**Observe the requirements for the communication cable**

The communication cable must comply with the requirements described in 6.1. Especially in the case of longer cable lengths, high-quality communication cables and connectors must be used to ensure that the signal quality is adequate.

- › KACO blueplanet hy-switch is also powered by the device via the communication cable.

## 8 Commissioning

### 8.1 Hardware commissioning



#### WARNING

##### Risk of electric shock



Before connecting or checking the DC cable (PV), make sure that the DC switch is in the OFF position.

- › Before connecting or checking the AC cable, make sure that the corresponding circuit breaker is switched off!

#### 1. Check the following points before commissioning:

1. The device must be safely and firmly mounted.
  2. Make sure the no-load voltage of the PV system meets the requirements.
  3. Make sure the no-load voltage of the public grid corresponds to the nominal value.
  4. Make sure the AC cable is correctly connected to the grid.
  5. Check the cabling of the PV modules.
- » If the points are in order, the device can be started.

#### 2. Starting the device

1. Switch on the public grid at the external, AC-side disconnecter mechanism.
  2. Make sure the battery storage unit is ready for operation and switch it on.
  3. Switch on the PV system with the DC isolator switch:  
Turn the DC isolator switch to the "I" position.
- » Now that the device is ready for operation, it will start operating as soon as sufficient voltage is applied to the PV input.

240 VDC is required for the start. After DC switch is turned on, the display does not come on until 60 seconds has elapsed! If the device does not respond after 60 s when voltage is applied, the DC disconnecter must be turned to the "0" position and the polarity of the PV connections must be checked.

If warnings/errors are displayed on the LCD display, a problem or error is present. Please consult chapter 9.3 of this manual for troubleshooting or contact your installer.

### 8.2 Configuration with the KACO blueplanet hy-switch software



#### NOTE



##### Configuration of the device

The device is configured using the blueplanet hy-sys software. This is available in the download area under [www.kaco-newenergy.de](http://www.kaco-newenergy.de).

↻ Download the latest version of the blueplanet hy-sys software.

1. **Observe the separate functional description of the blueplanet hy-switch software.**
2. Update the firmware of the device and its components. Please observe the software update sequence: 1. COM, 2. CONTROLLER, after that, other components.

3. Update the country settings of the device using country-specific setup files.
4. Set and check the software settings when commissioning the device.
5. Optional: Install existing function extension certificates.
6. Save all changes made in the *User Settingstab*.

### 8.3 Display

The display shows the device status. Current measurements and fault messages are displayed on this display. The various basic settings can be made on this display.

#### 8.3.1 Start display

After activation, the name of the device series is briefly displayed.

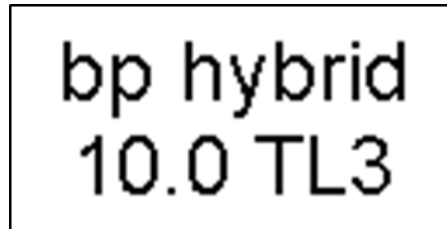

Fig. 32: Display of the device series

The figure shows the standby display in which you can see that the basic requirements for starting the system have been met. The PV system must have sufficient voltage for the start and the grid must be connected.

The display is divided into two areas.

The current status, extended measurements, error messages and selection menu are displayed in the left field. The right field displays basic measurements, the battery status and battery error messages.

The figure shows

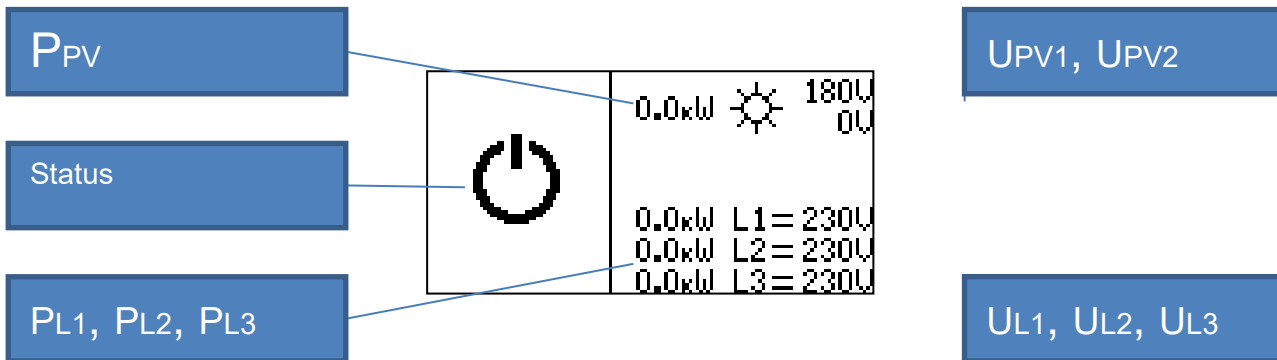

Fig. 33: Standby

- UPV1, UPV2 – Input voltage at PV connections
- PPV - Total power PV inputs, the sum of power outputs PPV1 and PPV2
- UL1, UL2, UL3 - Grid voltage at device connection terminals
- PL1, PL2, PL3 - Device output power per phase

An active Ethernet connection is indicated by the "e" symbol.



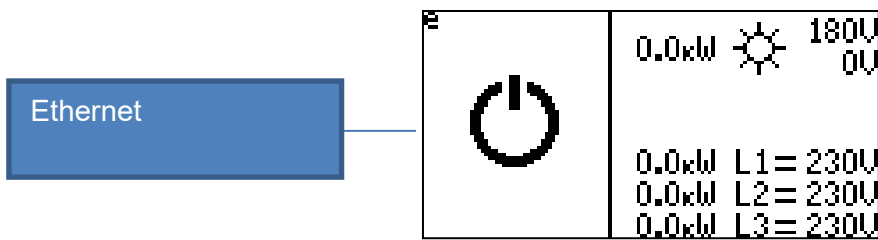

Fig. 34: Ethernet symbol "e"

As soon as the voltage of the solar generator exceeds the switch-on limit, the device goes into test mode. In the process, the system and the grid are checked.

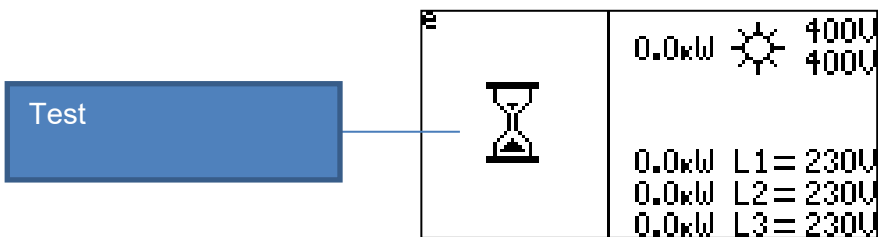

Fig. 35: Test mode display

### 8.3.2 Operating display

If the test is completed successfully, the device switches to grid operation. Grid operation is illustrated by the "House" symbol. The direction of energy transfer "PL direction" per phase can be recognised by the following symbols:

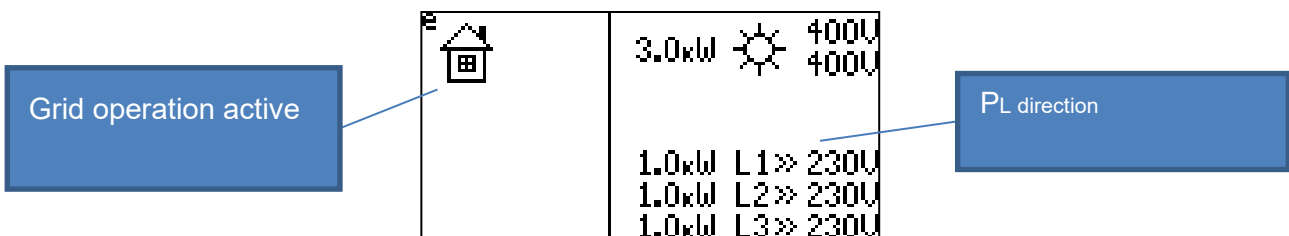

Fig. 36: Grid operation

- ">>" – Supply to grid
- "=" – No energy transfer
- "<<" - Energy is drawn from the grid
- The power delivered to the grid is equal to the current power on the solar generator:
- $P_{L1} + P_{L2} + P_{L3} = P_{PV}$ .

After blueplanet hy-switch has been connected and activated, the display shows the total household consumption  $P_{House}$ , the grid power  $P_{Grid}$  and the direction of energy transfer.

The device feeds into the grid.

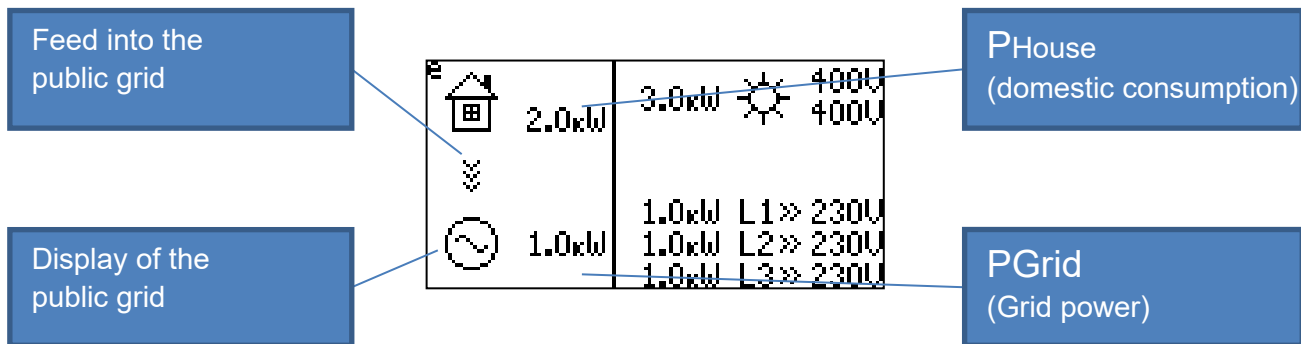

Fig. 37: Grid operation with hy-switch

- ">>>" - Energy surplus, energy is fed into the public grid
- "<<<" - Energy shortage, energy is drawn from the public grid
- "=" - No energy exchange takes place, self-consumption is fully compensated.
- The values P<sub>House</sub> and P<sub>Grid</sub> depend on the current household consumption and the power currently provided by the device:  $P_{House} + P_{Grid} = P_{L1} + P_{L2} + P_{L3} = P_{PV}$ .

The figure shows a compensated household consumption.

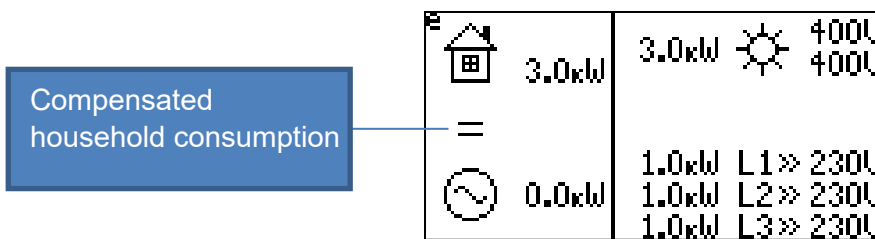

Fig. 38: Compensated household consumption

Household consumption is supplemented by public grid consumption.

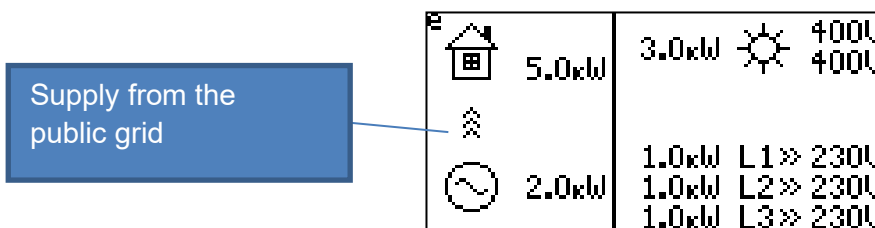

Fig. 39: Supply from the public grid

When operating on battery power, a battery symbol with information appears on the display: SOC = state of charge, battery voltage and operation mode (charge, wait, discharge).

The battery is discharged to cover the increased household consumption.

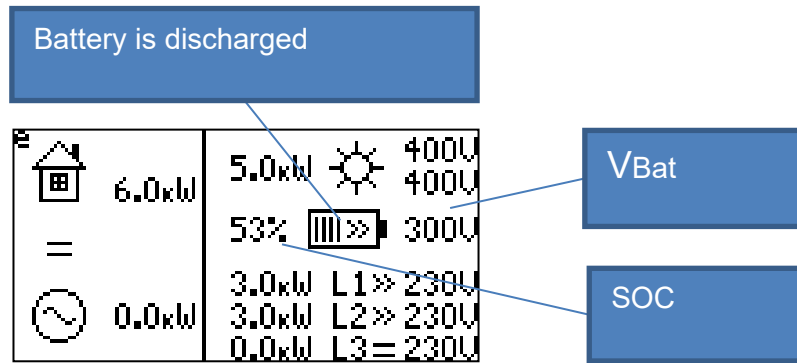

Fig. 40: Household consumption with battery discharge

- ">>" - The battery is being charged
- "<<" - The battery is discharged
- The values  $P_{House}$  and  $P_{Grid}$  depend on the current household consumption and the power currently provided by the device:  $P_{House} + P_{Grid} = P_{L1} + P_{L2} + P_{L3} = P_{PV} + P_{Bat}$ . The  $P_{Bat}$  battery power is not directly shown on the display.

The battery has an SOC of 100% and is in standby mode. The excess current is supplied to the grid.

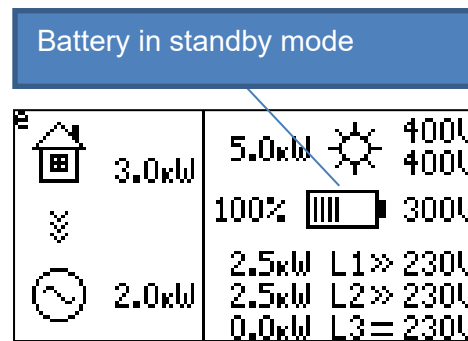

Fig. 41: Battery in standby mode

The lightning symbol indicates that either standalone or standby power operation is enabled in the device.

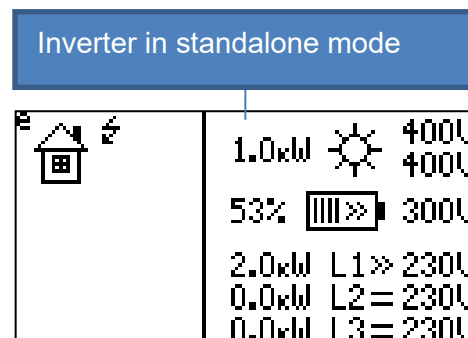

Fig. 42: Inverter in standalone mode

### 8.3.3 Selection menu

Use the selection menu to display device information. The hy-switch and battery mode can be activated in this way.

The selection menu is displayed by briefly pressing the red "Set" button. The active element is marked with a frame (position marker). In the selection menu, you can jump to the next selection by briefly pressing the "Set" button. To select and activate a menu, press and hold the "Set" button for about 2 seconds. The selection menu is exited with the back symbol (Exit).

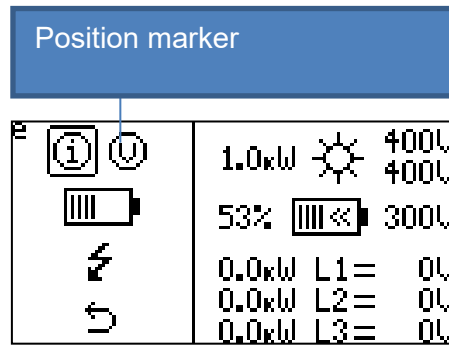

Fig. 43: Selection

Selection for device information

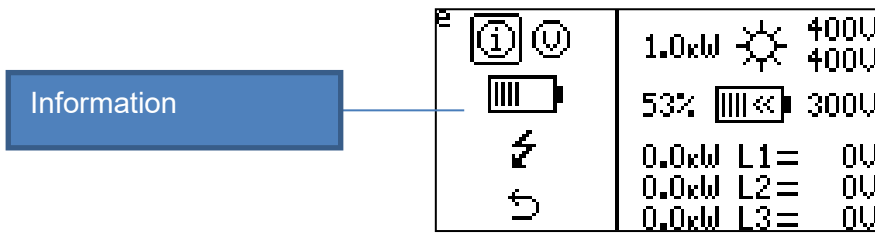

Fig. 44: Information

The information field shows: Versions of the individual software units (control, communication, blueplanet hy-switch), current date and time, the current temperature in the device, the currently assigned IP address, the serial number of the device and its MAC address. The information field closes when the "Set" button is pressed briefly.

The display shows the device-internal information.

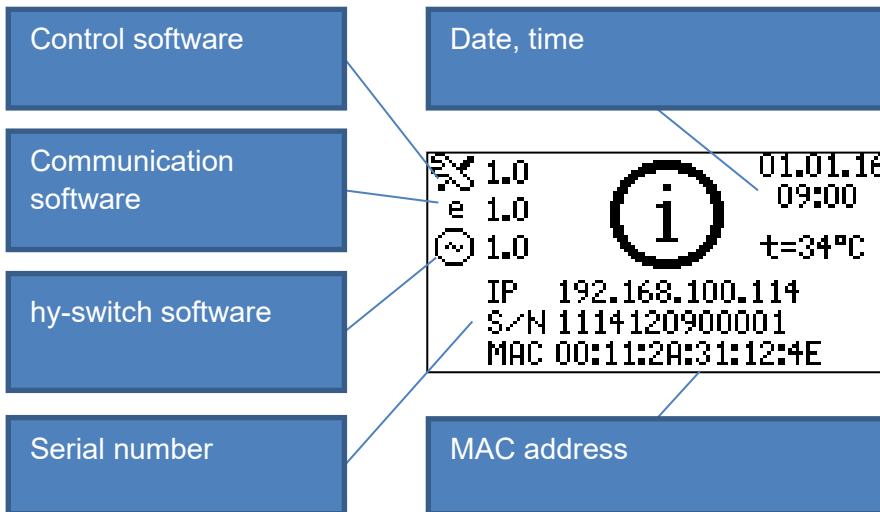

Fig. 45: Information field

Exit returns you to the higher-level menu.

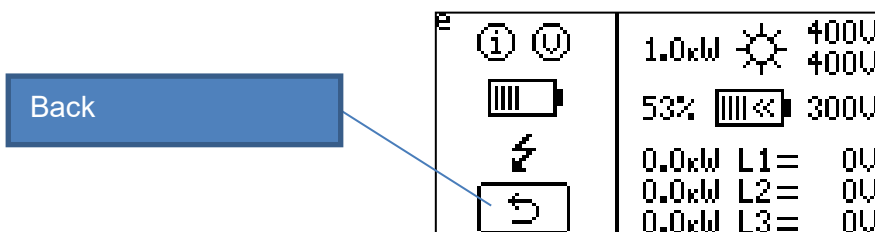

Fig. 46: Exit

### 8.3.3.1 Hy-Switch

The hy-switch determines the power consumption of the house. Before use, the hy-switch must be configured in the hy-sys configuration software.

The configuration of the hy-switch can be displayed on the unit. Selection of hy-switch.

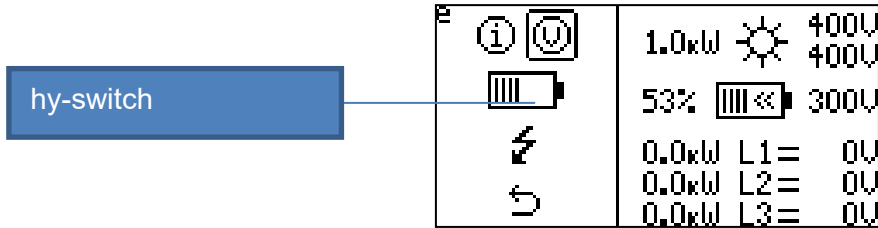

Fig. 47: hy-switch symbol

Display of the configured current sensors for hy-switch.

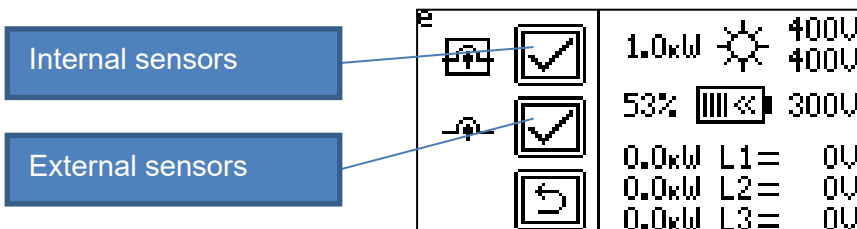

Fig. 48: Selecting the current sensors

### 8.3.3.2 Battery

Use the selection to activate the battery. Selection for connecting the battery.

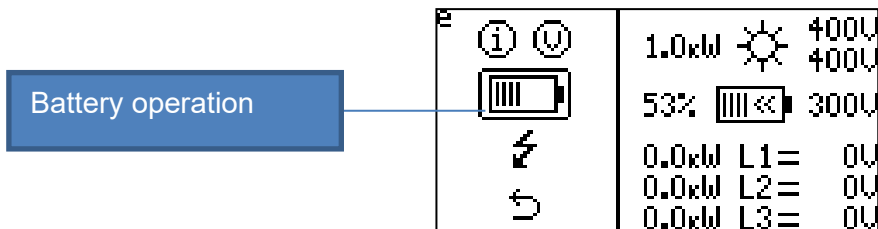

Fig. 49: Battery symbol

The battery can be switched on or off. When the battery is connected, a one-time search process is performed in which the battery type is automatically detected. The search procedure can take a few minutes.

Connecting the battery.

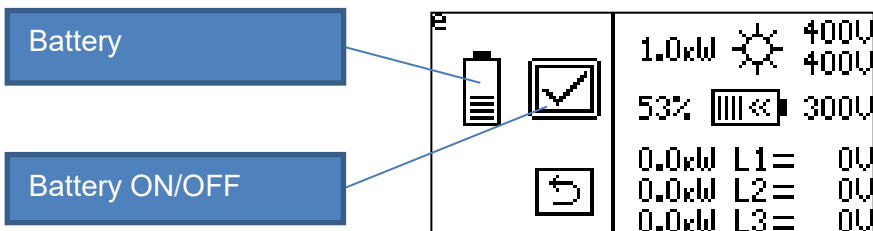

Fig. 50: Battery selection

### 8.3.3.3 Disconnection from standalone or standby power operation

With the selection, standalone or standby power operation can be disconnected. Disconnection requires the corresponding function extension certificate.

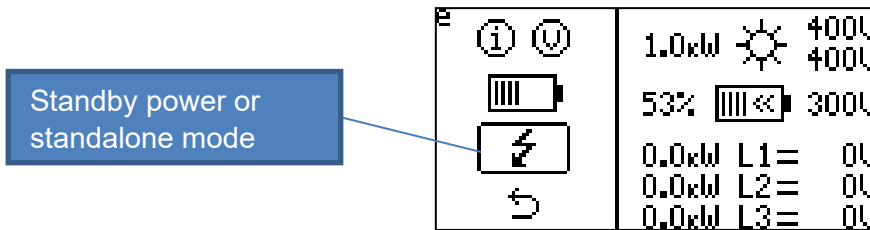

Fig. 51: Standalone or standby power symbol

Disconnecting the standby standalone power function.

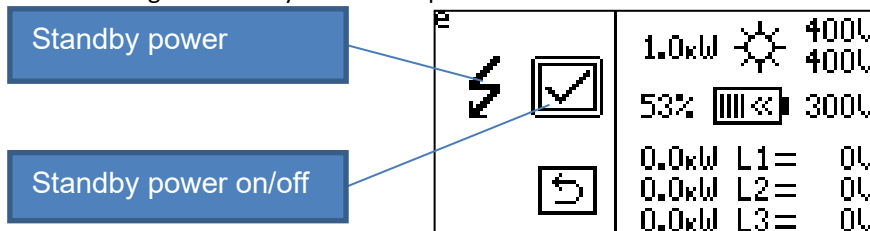

Fig. 52: Standalone or standby power disconnection

### 8.3.3.4 Disconnection from standalone or standby power operation

The selection can be used to activate standalone or standby power operation.

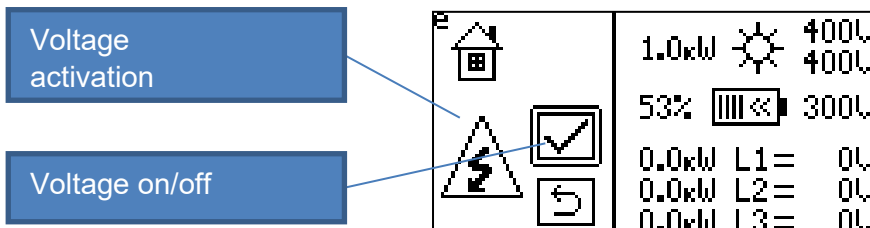

Fig. 53: Standalone or standby power activation

The menu is displayed when the standalone or standby power operation is ready and can be activated. To stop standalone or standby power operation, the menu can be called up by briefly pressing the SET button.

### 8.3.3.5 Password

All changes must be confirmed and enabled with the password. Password assignment can be used to protect against access by unauthorised persons. The password is activated in hy-sys. The activation is described in the hy-sys manual.

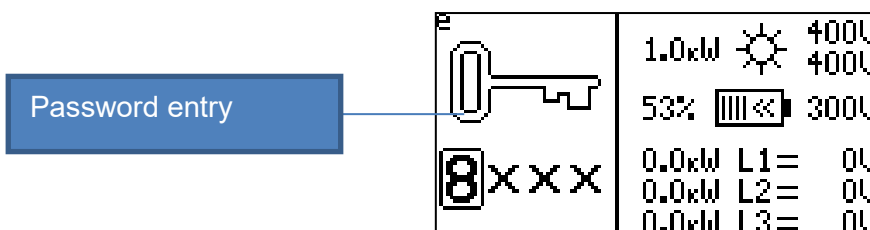

Fig. 54: Password

### 8.3.4 Switching off the inverter

The system is shut down by pressing and holding the "Set" button (longer than 5 seconds). The batteries are disconnected from the system.

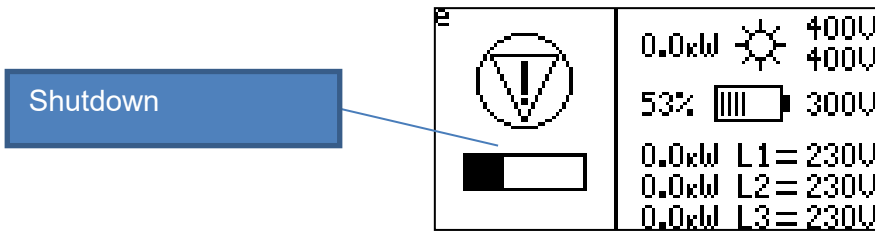

Fig. 55: Progress bar during shutdown

After the device has been shut down, the PV switch must be set to position 0 to switch the device off completely.

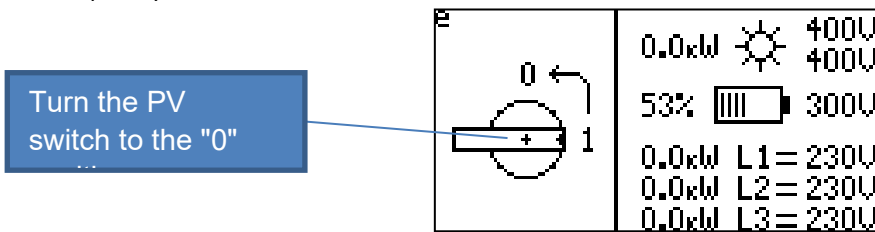

Fig. 56: Turning off the PV switch

After switching off the device, check that the connected battery is safely disconnected with the main switch.

### 8.3.5 Warning/fault

If the device is in a warning or error state, a warning (A) or fault (E) message is displayed. Up to three messages can be displayed simultaneously.

Display of warning messages / fault messages on the display.

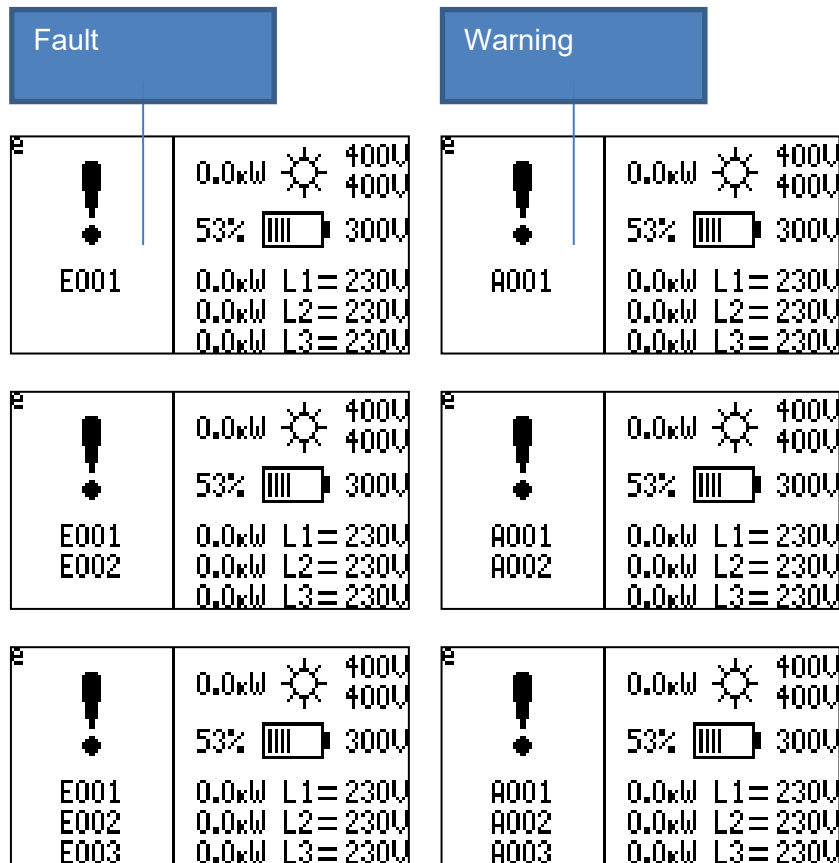

Fig. 57: Faults and warnings on the display

The warning messages / fault messages are listed in chapter 9.3.

If the battery is in a warning or fault condition, the battery is shown flashing.

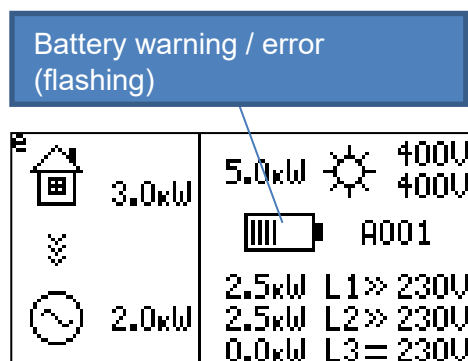

Fig. 58: Battery warning/fault



### 8.3.6 Warning display

The measurements that lie outside the operating limits are displayed flashing.

As an example: If the voltage on the solar generator has not yet reached the switch-on limit, the PV voltage is displayed flashing.

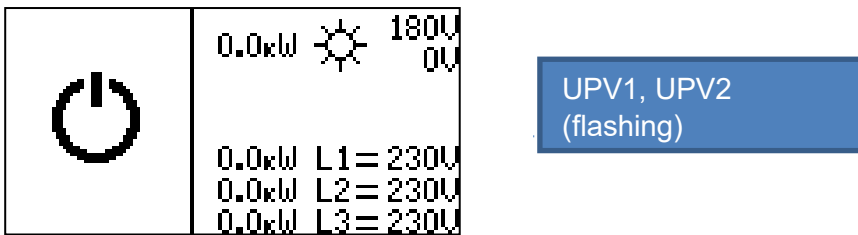

Fig. 59: Flashing display

## 8.4 Update

During the update, sufficient sunlight must be ensured. The device is restarted after the update, requiring sufficient PV power for this purpose.

### CAUTION

#### No PV power

If no PV power is available, deactivating the battery can cause the device to shut down completely.

- › Reactivation is only possible when the PV modules once again provide enough power to turn on the system.

#### When updating the COM

COM update

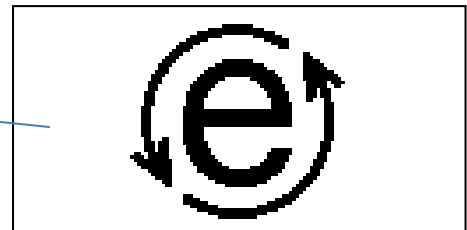

Fig. 60: Symbol when updating the COM

#### When updating the control

Control update

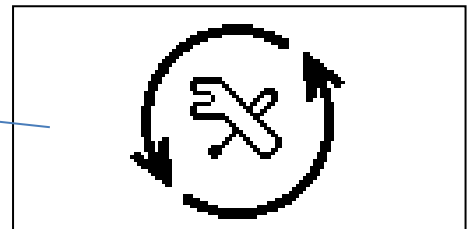

Fig. 61: Symbol when updating the control

#### When updating the hy-switch

hy-switch update

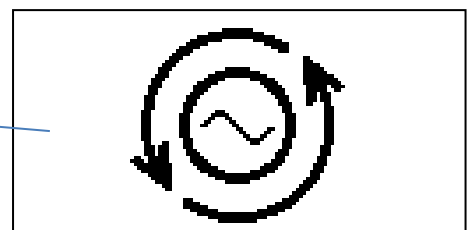

Fig. 62: Symbol when updating hy-switch

## 9 Maintenance and troubleshooting

### 9.1 Visual inspection

#### DANGER

##### Risk of fatal injury due to contact voltages!

Removing the plug connections before disconnecting the device from the PV generator may lead to injuries and damage the device.



- › During installation: Electrically disconnect the DC positive and DC negative from the protective earth (PE).
- › Disconnect the device from the PV generator using the integrated DC isolator switch.
- › Remove the plug connector.

#### DANGER

##### Dangerous voltage due to two operating voltages

Severe injuries or death may occur if the cables and/or terminals/busbars in the device are touched. The discharge time of the capacitors is up to 5 minutes.



#### NOTE

##### Opening the device is not permitted, as this will invalidate the warranty



Do not attempt to eliminate faults that are not described here (in chapter "Warning messages / fault messages"). Contact our Customer Service department. Only perform the maintenance work that is described here.

The device should be checked for proper operation by a qualified electrician at regular intervals and if you experience problems, you should always contact the system manufacturer's Service department.

1. Inspect the device and the cables for visible external damage.
2. Check all connections for a firm seat and cleanliness.
3. Pay attention to the operating displays and messages on the display.
4. Inspect the device from the outside to see if it is infested with vermin.

In the event of damage, notify your installation engineer. Repairs may only be carried out by authorised electricians.

## 9.2 Cleaning

### 9.2.1 Cleaning the housing

#### DANGER



#### **Danger of death due to penetrating fluid**

Serious injuries or death can result if moisture enters the system.

- › Only use completely dry objects to clean the device.
- › The device should only be cleaned from the outside.
- › Do not use a high-pressure cleaner.

#### CAUTION



#### **Risk of burns from hot surface.**

Heat sinks become very hot when in operation.

- › Never touch the heat sinks after commissioning the device.
- › Allow the heat sinks at least 10 minutes to cool down before cleaning.

#### CAUTION

#### **Damage to the housing parts when using cleaning agents!**

- › If the device is contaminated, only clean the housing, cooling fins, housing cover, display and the LEDs with a cloth.

#### NOTE



#### **Refer to our service and guarantee conditions on our homepage.**

- › The cleaning intervals must be adapted to the environmental conditions of the installation site.
- › In sandy environments, we recommend a ¼-yearly cleaning of the heat sink.

1. Clean the device whenever it gets dirty, preferably during the cooler times of the day.
2. Use a vacuum cleaner or a soft brush to remove loose dust from the top side of the device and the heat sink on a regular basis.
3. Clean the space between the cooling ribs with a suitable brush.



Fig. 63: Radiator fins and top air outlet

4. If necessary, remove coarse dust from the ventilation inlets on the bottom of the device.

## 9.3 Warning messages / error messages / information

### 9.3.1 List of warning messages

Warnings indicate a temporary device shutdown. The device restarts automatically once the cause of the warning has been eliminated.

Code	Meaning	Explanation / recommendation
A001	Grid voltage: Undervoltage	The device monitors the voltage level in the grid. If the voltage falls below the configured limit values, the device stops and only starts up again once the voltage value is back within the limits.
A002	Grid voltage: Overvoltage	The device monitors the voltage level in the grid. If the voltage exceeds the configured limit values, the device stops and only starts up again once the voltage value is back within the limits.
A003	Grid voltage: Overvoltage 10%	The voltage of the individual phases is higher than 10% above the nominal value. If this is the case for more than ten minutes, the device stops supplying and only switches on once when the voltage drops below this limit.
A004	Grid voltage: Linked undervoltage	The device is equipped with three-phase grid monitoring, which is used for island formation detection. If the three-phase grid conditions do not correspond to the limit values entered, the device switches off.
A005	Grid voltage: linked overvoltage	The device is equipped with three-phase grid monitoring, which is used for island formation detection. If the three-phase grid conditions do not correspond to the limit values entered, the device switches off.
A006	Grid voltage: Undervoltage	The device monitors the voltage level in the grid. If the voltage falls below the configured limit values, the device stops and only starts up again once the voltage value is back within the limits.
A010	Insulation resistance	The device monitors the insulation resistance of the PV modules and battery to earth. If the insulation resistance is too low, it may indicate that the insulation is damaged.
A021	Leakage current: Personal protection 30mA	The device monitors the leakage current to earth. If a rapid change in the leakage current is detected, the device switches off and repeats the insulation measurement. If the insulation resistance is OK, the device switches on again.
A022	Leakage current: Fire protection 300mA	The device monitors the leakage current to earth. If a high leakage current is detected, the device switches off and repeats the insulation measurement. If the insulation resistance is OK, the device switches on again.
A031	Undertemperature	The device is not suitable for operation below 5°C.

A032	Overtemperature	The cooling is not sufficient. The ambient temperature must not exceed 40°C. Check the device position and installation site.
A040	Island formation	The device has detected that the power connection to the public grid has been shut off. Check the grid connection.
A050	Frequency shift	The grid frequency is unstable. This can occur due to a grid overload or oversupply of energy in the grid. Find out about local grid conditions.
A060	DC current injection	The device monitors the DC component of the output current. If an increased DC component is detected in the supplied current, the device stops the supply. This problem can be caused, for example, by quick-moving cloud cover.
A071	Connection conditions not met (grid voltage)	Connection to the grid is only permitted if the grid is stable, otherwise an additional grid supply can increase grid instability. For this reason, the device checks the stability of the grid before each connection.
A072	Connection conditions not met (grid frequency)	Connection to the grid is only permitted if the grid is stable, otherwise an additional grid supply can increase grid instability. For this reason, the device checks the stability of the grid before each connection.
A081	Grid voltage: FRT overvoltage	Check grid voltage. Check the setting values in the Setup menu. Check the AC cabling of the inverter.
A082	Grid voltage: FRT undervoltage	Check grid voltage. Check the setting values in the Setup menu. Check the AC cabling of the inverter.
A100	blueplanet hy-switch: Wiring fault	Phase, neutral or earth connections are mixed up on blueplanet hy-switch, the input and output positions do not match on the blueplanet hy-switch, or the phase position on the hy-switch and blueplanet hybrid 10.0TL3 do not match.
A111	blueplanet hy-switch: PE connection	Problems with the earth potential of hy-switch.
A112	PE connection on device unavailable	The PE connection is not connected to the device or it has been incorrectly connected. Check the installation.
A120	Setting parameters	The device could not be configured from EEPROM. Contact Service. Note: During commissioning, the grid operator settings must be made once in the hy-sys software.
A121 A122	Setting parameters	EEPROM can not be written because not enough supply voltage is available. Make sure that the PV voltage amounts to at least 240V.

A123 A124	Setting parameters	The EEPRPOM cannot be read. Contact Service.
A125	Unsaved changes	Settings have been made on the device, but have not yet been saved. If necessary, the settings can be saved under <i>User Settings</i> .
A130	Check supply settings	Check the $P_{av,e}$ and $P_{feed\_in\_limit}$ settings. The fault will occur if $P_{feed\_in\_limit} > P_{av,e}$ .
A140	Wiring error N-PE	Missing connection N-PE in the standalone grid or standby circuit.
A150	Overload in standalone mode	Overload of the inverter.
A151	Overload in standalone mode	Asymmetrical overload of the inverter.
A152	DC voltage share	The DC voltage share in the standalone grid is too high. Pay attention to suitable consumers.
A160	Hy-switch: Communication	Hy-switch activated but cannot be addressed.
A171 A172	Hy-switch: Connecting cable	Connecting cable between device and hy-switch too long or defective.
A173	Hy-Switch: Voltage N-PE	Voltage between N and PE too high (over 50 V). Check the installation.
A200	Battery: Undervoltage	Connected battery has a voltage lower than 96 V.
A240	Battery communication	The device cannot communicate with the battery. Check the communication connection to the battery, including the pertinent software settings.
A250	Battery wiring fault	The measured battery voltage does not correspond with the battery voltage determined in the BCU (Battery Control Unit).
A260	Battery not found	The device cannot communicate with the battery. Check the communication connection to the battery, including the pertinent software settings.
A270	Standalone grid voltage	Standalone grid voltage too high after disconnection (over 50 V). Check for other voltage sources and wiring faults.
A281	Battery fault condition	Battery reports an error. Check at the battery.

### 9.3.2 List of error messages

Faults indicate states of the device where a defect may exist or which may cause a defect. If faults occur repeatedly or regularly, KACO Service must be informed and the device decommissioned.

Code	Meaning	Explanation / recommendation
E001	Overvoltage solar generator input 1/2	Turn off the DC switch immediately, and check the voltage at the PV connection. Your device is approved for a maximum solar generator no-load voltage of 900V. Higher input voltages can damage the device.
E002	Overvoltage solar generator input 2/2	Turn off the DC switch immediately, and check the voltage at the PV connection. Your device is approved for a maximum solar generator no-load voltage of 900V. Higher input voltages can damage the device.
E011 E012	Grid overvoltage	Voltage at the grid connection is too high or has a high noise level. Check the grid voltages. A grid filter may be necessary. A more frequent occurrence of the fault can reduce the service life of the device.
E021 E022 E023 E024 E025	Device fault	DC link voltage. Inform the service technician in case of repeated faults.
E030	Battery overvoltage:	Switch off the battery and check the voltage at the battery connections. A high input voltages can damage the device (if the fault is present for a longer period of time). May also occur when the battery is switched off due to another fault.
E041 E042	Initialisation error leakage current	The leakage current (residual current) is too high. Check the operating conditions, and contact the service technician if necessary.
E051 E052	Grid overcurrent	Severe grid disturbances or failures may result in overcurrent in the device under certain circumstances. The device shuts down to protect itself. Check the stability of the grid. Inform the service technician in case of repeated faults.
E060	General fault	Inform the service technician in case of repeated faults.
E070	AC relay: Self test initialisation error	Check the operating conditions. Inform the service technician in case of repeated faults.
E080	Battery DC relay Self test initialisation error	Check the operating conditions. Inform the service technician in case of repeated faults.
E090	Temperature sensor initialisation error	Check the ambient temperature and the temperature display on the device. Make sure that the device is being operated within the permissible temperature range.

E101 E102 E103 E104 E110	Device fault	Internal power supply Inform the service technician in case of repeated faults.
E120	Self test initialisation error	Check the operating conditions, and contact the service technician if necessary.
E130	General fault	Inform the service technician in case of repeated faults.
E140	General fault	Inform the service technician in case of repeated faults.
E150	Self test initialisation error	Check the operating conditions, and contact the service technician if necessary.
E160	General fault	Inform the service technician in case of repeated faults.
E170	Monitoring stop	May occur during a software update If this error occurs frequently during operation, please inform the service technician.
E180 E181 E182	Self test initialisation error	Inform the service technician in case of repeated faults.
E191	Battery service	General battery fault. Please check the battery fault log for the exact cause of the fault.
E200	General fault	Inform the service technician in case of repeated faults.
E211	EEPROM Initialisation error	The configuration data of the device cannot be read from EEPROM. Inform the service technician in case of repeated faults.
E220	Self test initialisation error	Inform the service technician in case of repeated faults.
E230	General fault	Inform the service technician in case of repeated faults.
E240 E241	Hy-switch defect	Defect of the Hy-switch hardware
E250	disconnecting from the grid	Hy-switch cannot disconnect neutral conductor. Check installation
E251	disconnecting from the grid	Hy-switch cannot close neutral conductor. Check installation
E300	Battery overvoltage:	Check installation of the battery
E9xxx	General fault	Inform the service technician in case of repeated faults.



## List of displayed information

Information indicates limitations of the device functions.

Code	Meaning	Explanation / recommendation
I001	Heat sink temperature	The temperature of the heat sink is too high. The power is reduced. Check the installation.
I002	Temperature of hy-switch	The internal temperature of hy-switch is too high. Check the installation.
I003	Battery temperature	The battery temperature is too high. The battery power is reduced.
I010	Power reduction	The energy supplier has reduced the power of the device. Wait until the power setting changes.
I031 I032	Deactivation by button	Device has been switched off by button.
I040	Battery charge balancing	The connected batteries have very different states of charge. Charge balancing of the battery is recommended.
I121	Supply settings	The setting of $P_{av,e}$ is lower than $P_{feed\_in\_limit}$ . Check the settings in the device.
I122	Supply settings	External power target is greater than $P_{av,e}$ . Check settings.
I141	Communication of hy-switch	hy-switch is switched to active, but cannot be addressed. Check the system components of hy-switch
I142	Battery communication	The battery is switched to active, but cannot be addressed. Check the battery
I171	Safety	The initial password has not been changed. Change password.
I201	Standalone mode	Hy-switch is connected when standalone mode is activated. Check configuration
I202	Standalone mode	AC voltage present. The inverter does not build up a standalone grid. Check the installation.
I203	Standalone mode	Battery cannot be discharged. The inverter does not build up a standalone grid.
I204	Standalone mode	Battery is discharged. The inverter shuts down.
I401	Standby power function	Battery state of charge too low (below 10%). The inverter does not build up a standby power grid
I901	Reset	The device restarts after a software update.
I902	Battery configuration	The device performs the detection of the connected battery. Wait until the battery is detected. If persistent, check connection.
I903	Commissioning	Device has not yet been commissioned or sufficiently configured. Perform the commissioning procedure.
I904	FRT undervoltage	FRT undervoltage detected Wait until the result is no longer present. If it persists, check the installation.
I905	FRT overvoltage	FRT overvoltage detected Wait until the result is no longer present. If it persists, check the installation.

I906	Power reduction overfrequency	Power reduction due to overfrequency. Wait until the result is no longer present.
I907	Power reduction underfrequency	Power reference due to underfrequency. Wait until the result is no longer present.
I908	Unsaved settings	New settings have been made on the device, but have not yet been saved. If necessary, the settings can be saved under <i>User Settings</i> .
I909	AC overvoltage	AC overvoltage detected. Wait until the result is no longer present. If it persists, check the installation.
I910	Software	Incompatible software versions. Update software
I911	hy-switch connection	Unstable connection to hy-switch. Check the installation.
I912	Power reduction overvoltage	Power reduction due to overvoltage. Wait until the result is no longer present.

## 9.4 Other faults

### Fault pattern:

Display without function and device cannot be switched on

### Possible solutions:

- The device runs without battery power and is shut down at night. It starts automatically the next day.
- The device runs without battery power and the power supply from the PV modules is interrupted. Check the position of the DC isolating switch and the fuse protection of the supply line. Contact your installer.
- The device has a power supply fault. Check the power supply and functioning of the battery. Contact your installer.

## 10 Decommissioning and dismantling

 **Authorised electrician**

### DANGER



**Lethal voltages are still present in the connections and cables of the device even after the device has been switched off and disconnected!**

Severe injuries or death may occur if the cables and/or terminals/busbars in the device are touched.

Only appropriately qualified electricians authorised by the mains supply network operator are permitted to open and maintain the device.

- › Comply with all safety regulations and current technical connection specifications of the responsible power supply company.

### DANGER



**Risk of fatal injury due to electric shock!**

The DC isolator switch only disconnects the PV generator from the device. The storage battery is not disconnected. Voltage is still present at the DC connector BAT.

Severe injury or death will result if the live connections are touched.

- › Only touch the PV generator cables on the insulation. Do not touch the exposed ends of the cables.

### 10.1 Switching off the device



### WARNING

**Risk of burns caused by hot housing components**

Housing components can become hot during operation.

- › During operation, only touch the housing cover on the device.

1. Press and hold the "Set" button (on the bottom of the device). A status bar appears on the display. The "Set" button must be pressed until this bar is completely filled and the request to operate the DC isolator switch appears on the display.
2. The device discharges. The display goes out after about 60 seconds.
3. Set the DC isolator switch to "0" to prevent unintentional starting.

### NOTE



**If the display is dark, the device does not necessarily have to be switched off permanently.**

- › To prevent the device from starting, the DC switch must be set to "0".

## 10.2 Uninstalling the device

 **Authorised electrician**



 **DANGER**

### **Dangerous voltage due to several operating voltages**

Severe injuries or death may occur if the cables and/or terminals/busbars in the device are touched. The discharge time of the capacitors is up to 5 minutes.



- › The device is supplied on the DC side from the PV system and the battery storage unit.
- › The device can be connected to the public power grid on the AC side.

 **DANGER**



### **Do not open the device! All connections are externally accessible.**

**Lethal voltages are still present in the connections and cables/terminals of the device even after the device has been switched off and disconnected!**

- › Severe injuries and/or death may occur if the cables and terminals are touched.

↻ The device and storage battery are disconnected from the power supply and secured against being switched on again.

↻ Device is switched off, and the DC switch is in position "0".

1. Disconnect DC connections of the battery, see 10.2.1.
2. Disconnect DC connections of the PV generators, see 10.2.1.
3. Disconnect the three communication cables BAT, hy-switch, LAN, see 10.2.2.
4. Disconnect AC connector, see 10.2.3.

### 10.2.1 Disconnecting the DC connector

 **Authorised electrician**

 **DANGER**



#### Destruction of the DC plug connectors

DC plug connectors can be destroyed by an arc event if disconnected while still live. It is absolutely essential that the following shutdown sequence be carried out in the correct order:

- › Check that there is no current in any of the DC cables using a clip-on ammeter.
- › Disconnect all DC connections one by one.

- ⌚ Ensure that the device is completely free of AC/DC voltage.
- ⌚ Check that there is no current using a clip-on ammeter.

**Plug connectors may be unplugged under voltage, but never under load.**

1. Use a screwdriver [~~X~~S\_3.0] to push out the latch on the coupling.
2. Leave the screwdriver in place.
3. Disconnect the DC connector from the DC socket.

1 Screwdriver

2 Latch

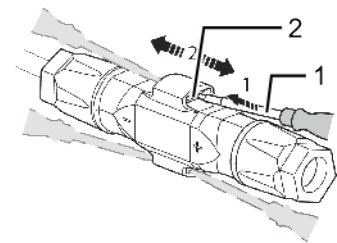

Fig. 64: Unplugging the plug connector

### 10.2.2 Disconnecting the communications cable

1. Carefully press down the retaining lug on the RJ45 connector.
2. Remove the RJ45 connector from the socket.

### 10.2.3 Disconnecting the AC connector

 **Authorised electrician**

 **CAUTION**

#### Plug in or disconnect connectors

Never connect or disconnect the connectors under load.

- › The connectors are not suitable for disconnecting the power.

1. Disengage the two connectors by pressing down the retaining lug with a screwdriver.
2. Remove the DC connector.

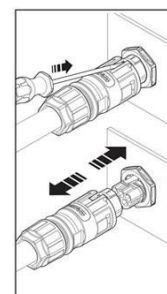

Fig. 65: Disconnecting the DC connector.

## 10.3 Disassembling the device

### CAUTION



#### Risk of injury from improper lifting and transport

If the device is lifted improperly, it can tilt and result in a fall.

- › Always lift the device vertically.
- › Use a climbing aid for the chosen installation height.
- › Wear protective gloves and safety shoes when lifting and lowering the device.

⌚ The device has been switched off and uninstalled.

1. Remove both countersunk screws [X\_A\_2.5] on the left and right side of the cover to secure it against being lifted off.
2. Move the bottom part of the device away from the wall at an angle of about 30°.
3. Disengage it from the wall bracket at the top.

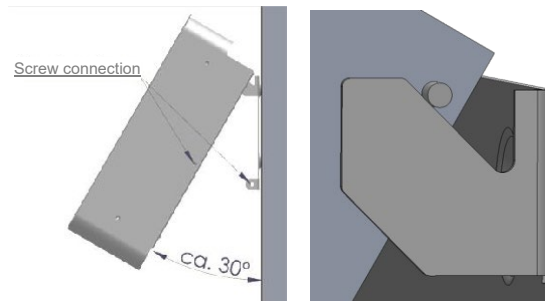

Fig. 66: Tilt the device 30° and disengage it from the wall bracket.

## 10.4 Packaging the device

⌚ Device has been uninstalled.

1. If possible, always pack the device in the original packaging. If this is no longer available, an alternative is to use equivalent packaging.
2. You must be able to close the box completely and it must be able to accommodate the weight and size of the device.

## 10.5 Storing the device

### CAUTION

#### Property damage as a result of condensation

Faulty storage can form condensate in the device and impair the device functioning (e.g. storage outside the ambient conditions or temporary relocation from a cold to a hot environment).

- › Store it according to the environmental data (see chapter 4.3)

⌚ Device packaged.

1. Store the device in a dry place according to the environmental data (see 4.3).

## 11 Disposal

### CAUTION



#### Risk to the environment if disposal is not carried out in the correct manner

For the most part, both the device and the corresponding transport packaging are made from recyclable raw materials.

Unit: Do not dispose of faulty devices or accessories together with household waste. Ensure that the old devices and any accessories are disposed of in a proper manner.

Packaging: Ensure that the transport packaging is disposed of properly.

The device complies with the relevant provisions of the RoHS Directive for the European Union. Like all other electrical and electronic products (EEE), it must not be disposed of as household waste.

The KACO new energy brand is registered in Germany under WEEE reg. no: DE 57110363.

## 12 Service and warranty

If you need help solving a technical problem with one of our KACO products, please contact our service hotline. Please have the following information ready so that we can help you quickly and efficiently:

- Device name / serial number
- Date of installation / Start-up report
- Fault message shown on the display / Description of the fault / Did you notice anything unusual? / What has already been done to analyse the fault?
- Module type and string circuit
- Consignment identification / Delivery address / Contact person (with telephone number)
- Information about the accessibility of the installation site.

You can find the following items and other information at our website [Kaco-newenergy.de](http://Kaco-newenergy.de):

- our current warranty conditions,
- a complaint form,
- A form for registering your device. Please register your device without delay. In this manner, you can assist us in providing you with the quickest service possible.



### NOTE

The maximum length of the warranty is based on the currently applicable national warranty conditions.



Werner-von-Siemens-Allee 1 · 74172 Neckarsulm · Germany · Tel. +49 7132 896-0 · info@kaco-newenergy.de ·  
www.kaco-newenergy.com



The text and figures reflect the current technical state at the time of printing. Subject to technical changes. No liability for printing errors.

3014696-02-220805