

KeContact P20/P30

Quick Installation Guide



Pay attention to the handling instructions, safety notes and installation guidelines in the "KeContact P20/P30 Installation manual"!



WARNING!

Not observing the safety instructions can result in risk of death, injuries and damage to the device! KEBA AG assumes no liability for claims resulting from this!

- **Electrical hazard!**
The installation, commissioning and maintenance of the charging station may only be performed by correctly trained, qualified and authorized electricians who are fully responsible for the compliance with existing standards and installation regulations.
- Only connect voltages and circuits in the right-hand connection area (Ethernet, terminals for control lines) that have a secure separation to dangerous voltages (e.g. sufficient isolation).

① Specifications for the electrical connection



The charging station is set to 10 amps in the delivery state. Set the maximum EVSE current capacity by setting the DIP-switches in coordination with your installed line circuit breaker (see chapter "DIP-switch settings").

The mains supply line must be hardwired to an existing house installation and correspond to the nationally applicable legal conditions.

Selection of the RCD circuit breaker:

- Each charging station must be connected to a separate RCD circuit breaker. No other circuits may be connected to this RCD circuit breaker.
- Residual-current device of at least type A (30 mA triggering current).
If the vehicles to be charged are not known (e.g. semi-public area), measures must be taken for protection where DC residual currents (>6 mA) occur. This can be realized, for example, through device version KC-P30-xxxxxx2, the use of an RCD type specifically intended for electric vehicles or with a RCD type B. The vehicle manufacturer specifications must also be observed.
- If a charging station is protected with a type B residual-current device, every upstream residual-current device, even those not assigned to the charging station, must either be type B or equipped with a DC residual-current detection device.

Dimensioning the Line circuit breaker:

- Determine the nominal current in accordance with the specifications on the type plate, in coordination with the desired charging current (DIP switch settings for the pre-adjusted maximum EVSE current capacity) and the mains supply line.

$$I_{DIPswitch} \leq I_{Breaker} \leq I_{Cable} \leq I_{Rating}$$

② Opening the connector panel

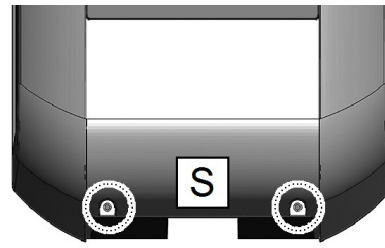

Cover screws

- ▶ Unscrew the two cover screws [S] on the bottom side of the housing cover.
- ▶ Remove the housing cover.

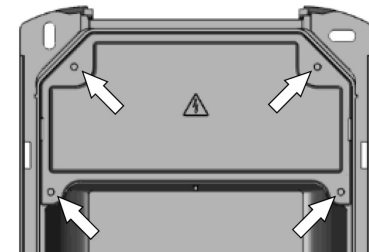

Removing the connector panel cover

- ▶ Unscrew the four screws with which the connector panel cover is mounted and remove the connector panel cover.

③ Preparing the cable insertion

TD-1609-018

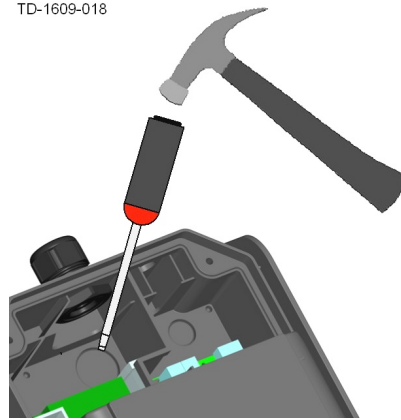

Breaking out the cable insertion openings

- ▶ Place the housing on a stable support pad and use a hammer and flathead screwdriver to carefully break out the required cable insertion openings.
- ▶ Then insert the corresponding feedthroughs (cable glands or double-membrane seals)



Use the cable gland when connecting from above!

④ Mounting the charging station

- ▶ Mark and drill the four holes using the supplied drilling template and a spirit level.

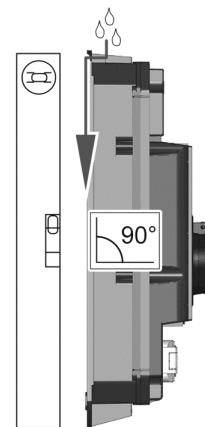

TD-1609-039

Water drainage

The water drainage from the top side to the rear side of the charging station must be ensured. Therefore, observe the following:

- Only a vertical installation of the charging station is permitted.
- The charging station must be mounted at an angle of 90° (no inclination is permitted!).

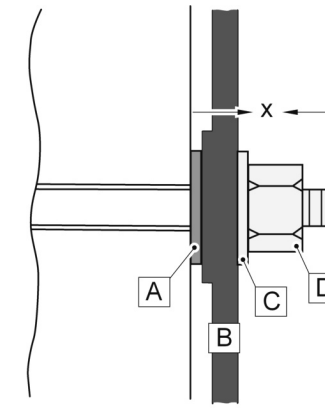

TD-1609-01

Mounting the charging station

- ▶ Turn the hanger bolts into the anchors until the thread still protrudes approx. 2 cm ('x').
 - ▶ Use the shims [A] to compensate for any unevenness and to ensure a water drainage behind the device.
 - ▶ Position and mount the charging station using the supplied washers and nuts.
- [A]...shim
[B]...charging station housing
[C]...washer
[D]...nut

⑤ Electrical connection



The cable sheathing must reach into the housing.

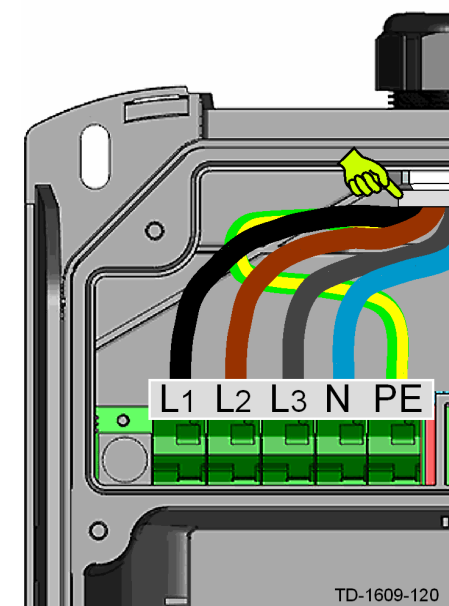

TD-1609-120

Connecting the mains supply line

- ▶ Shorten the connection wires to the appropriate length; these should be kept as short as possible. The PE conductor must be longer than the remaining conductors!
- ▶ Strip approx. 12 mm from the connection wires. Wire end sleeves are recommended for finely stranded wires.
- ▶ Perform the connection of the mains supply line [L1], [L2], [L3], [N] and [PE].

1-phase connection

It is also possible to perform a 1-phase connection of the charging station. Use the terminals [L1],[N] and [PE].

Supply terminals

The supply terminals are designed as spring-type terminals.

- ▶ Insert the flathead screwdriver (blade with 5.5 mm) into the supply terminal as shown on the picture.

Terminal data:

- inflexible (min.-max): 0.2 – 16 mm²
- flexible (min.-max): 0.2 – 16 mm²
- AWG (min.-max): 24 – 6
- flexible (min.-max) with wire end sleeve: Without/with plastic sleeve 0.25 – 10 / 0.25 – 10 mm²
- Stripping length: 12 mm
- Flathead screwdriver: 5.5 mm

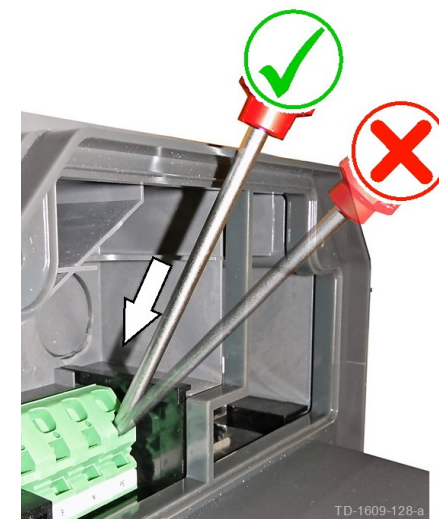

TD-1609-128-a

⑥ DIP-switch settings



Position of the DIP-switches DSW1/2

[DSW1]...configuration
[DSW2]...addressing

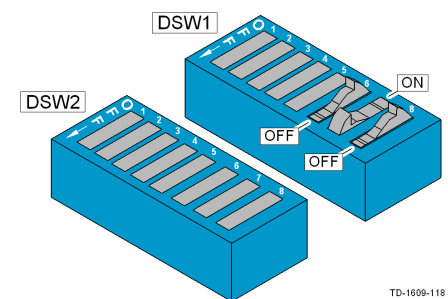

Amperage settings with DSW1

Example setting for 16A.

SETTING THE AMPERAGE (DSW1) (*1)					
Current	D1.6	D1.7	D1.8	Figure	Min. cable cross section
10A	OFF	OFF	OFF		≥ 1.5 mm ²
13A	ON	OFF	OFF		≥ 1.5 mm ²
16A	OFF	ON	OFF		≥ 2.5 mm ²
20A	ON	ON	OFF		≥ 2.5 mm ²
25A	OFF	OFF	ON		≥ 4.0 mm ²
32A	ON	OFF	ON		≥ 6.0 mm ²

(*1) Preadjusted maximum current value for the EV charger (control pilot duty cycle).

■...Indicates the position where to push down the DIP switch.

⑦ General commissioning process

1. Remove all residual installation and connection materials from the connection area.
2. Before commissioning, check all screw and terminal connections for firm seating!
3. Check whether all unused cable glands are properly sealed with blind plugs or dummy screw fittings.
4. Ensure that the voltage of the mains supply line is switched on. After 15 to 20 seconds, the status LED must flash green slowly. The device performs a self test every time it is switched on.
5. Perform the specified initial tests according to the locally applicable regulations and laws.
6. Close the connector panel cover to the charging station.
7. Mount the housing cover.

Commissioning mode

The charging station can be placed into a commissioning mode for supporting the initial system test. During this, a self-test of the device is performed (interlocking, contactor activation, current measurement, etc.) and a possible error is indicated.

After successful test without connected vehicle, the contactor is switched for limited time in order to facilitate the initial tests. A normal charging procedure is not possible in commissioning mode. The interlocking of the connector socket is activated to prevent a cable from being plugged in.

Switching on the charging station in commissioning mode via the supply voltage leads for security reasons in an error state (white-red-red-red) to prevent an unattended activation.

Activating the commissioning mode

- ▶ Set the DIP-switch **DSW2.8** to **ON**.
- ▶ Perform a reset of the charging station. To do this press the **[Service button]** for **1 second**.
The commissioning mode is now activated and is indicated by the orange status LED (lights continuously).
- ▶ You now have the option for approximately 10 min. to contact with standard test probes using the measuring device (e.g. Astaco® test probes from BEHA) and to perform the necessary tests.
After 10 min. have elapsed, the contactor is deactivated in the charging station is taken out of service.

Deactivating the commissioning mode

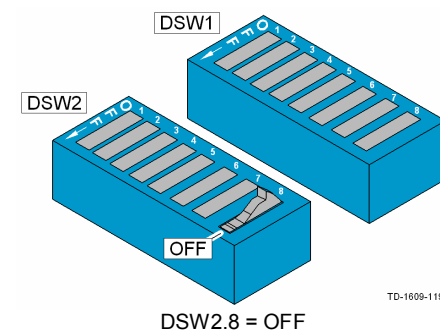

- ▶ Set the DIP-switch **DSW2.8** to **OFF** again.
- ▶ Perform a reset of the charging station. To do this, press the **[Service button]** for **1 second** or switch the power supply voltage off/on.

The charging station starts up again in normal mode and is ready for operation.

⑧ Closing the charging station

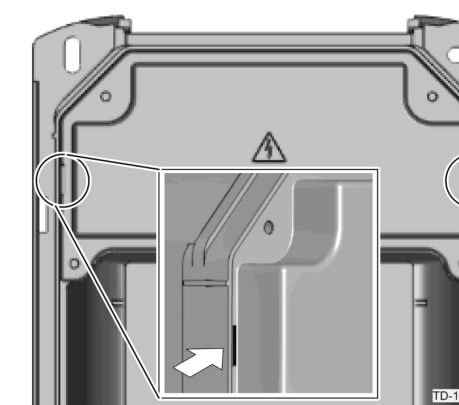

Housing mark

- ▶ Tighten the four screws until the mark on the connector panel cover is even with the housing surface.

The connector panel cover must seal the housing properly.

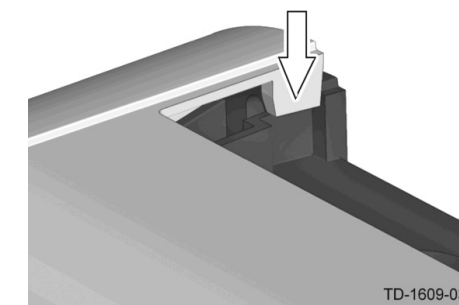

Fitting the housing cover

- ▶ Fit the housing cover at the top and push the cover downwards slightly.

Make sure that the housing cover is seated correctly at the top in the housing guides.

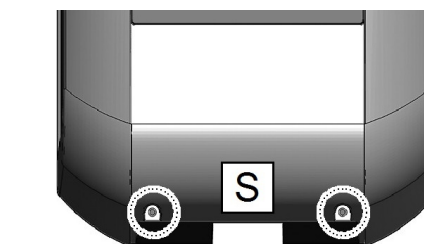

Cover screws

- ▶ Secure the housing cover at the bottom using the two cover screws **[S]**.

© KEBA 2014-2017

Subject to alteration in the course of technical advancement. No guarantee is offered for the accuracy of the information provided. All rights reserved.

All brand and product names are trademarks of their respective companies. Technical information in this document is subject to change without notice.

Document: Revision 3.10 / Release date: 19.07.2017 / Article no.: 93408

KEBA AG, Postfach 111, Gewerbepark Urfahr, A-4041 Linz; www.keba.com/emobility