



SHIFTING THE LIMITS



Fronius Agilo 75.0-3 / 100.0-3

EN

Operating Instructions

Grid-connected inverter



Dear reader,

Introduction

Thank you for the trust you have placed in our company and congratulations on buying this high-quality Fronius product. These instructions will help you familiarise yourself with the product. Reading the instructions carefully will enable you to learn about the many different features it has to offer. This will allow you to make full use of its advantages.

Please also note the safety rules to ensure greater safety when using the product. Careful handling of the product will repay you with years of safe and reliable operation. These are essential prerequisites for excellent results.

Contents

Safety rules	7
General information	11
Protection of people and equipment	13
Safety	13
Protection of people and equipment	13
Galvanic (electrical) isolation	13
Monitoring the grid	13
Warning notices on the device	14
Proper use	16
Proper use	16
Application area	16
Regulations governing the photovoltaic system	16
Functional principle	17
Functional principle	17
Cooling of the inverter through forced-air ventilation	17
Power derating	17
Solar module grounding	17
The inverter in a photovoltaic system	18
General	18
Tasks	18
Converting DC to AC current	18
Display function and data communication	18
System add-on	18
Description of the device	19
Outside of inverter	19
Inside the inverter	20
Connection compartment	21
Data communication area	22
Possible relay contact functions	25
Data communication and Solar Net	26
Solar Net and data interface	26
Overcurrent and undervoltage cut-out	26
Description of the 'Fronius Solar Net' LED	26
Example	27
Installation and commissioning	29
Choice of location	31
General comments regarding choice of location	31
Cabling into the inverter	31
Criteria influencing choice of location	32
Unsuitable locations	32
Transport	33
Transport	33
Transporting by its lifting eyes using a crane	33
Transporting by crane using pallet fork	33
Transporting by forklift truck or lift truck	34
Manual transport	34
Positioning the inverter	35
Prerequisites	35
Positioning the inverter	35
Notes regarding the air supply and the connection of an exhaust duct	36
Connecting the inverter to the public grid (AC)	37
Monitoring the grid	37
Mains connections	37
Connecting aluminium cables	37
Max. cross-section of AC cables	37
Safety	38

Connecting the inverter to the public grid	38
Connecting AC cables with a cable lug.....	41
Maximum fuse rating on alternating current side.....	41
Connecting an external AC supply for the inverter	41
Fitting and connecting optional overvoltage protection.....	42
General	42
Safety.....	42
Fitting and connecting overvoltage protection on the DC side.....	42
Fitting and connecting overvoltage protection on the AC side.....	43
Fitting and connecting overvoltage protection for the AC- supply.....	43
Connecting the DC cable to the inverter.....	45
General comments regarding solar modules.....	45
DC connections.....	45
Connecting aluminium cables.....	45
Max. cross-section of DC cables	45
Safety.....	46
Connecting DC cables	46
Connecting DC cables with a cable lug	47
Fuse protection against polarity reversal of DC cables.....	47
Grounding the solar modules in the inverter	48
General.....	48
Grounding the solar module to the negative pole via a fuse.....	48
Safety.....	49
Configuring the inverter for grounded solar modules.....	49
Grounding the solar module on the negative pole: inserting a fuse.....	50
Closing the inverter.....	51
Closing the inverter.....	51
Using for the first time	53
Factory configuration	53
Using for the first time.....	53
Configuring the inverter for existing solar module grounding.....	54

Operation **57**

Controls and indicators	59
Controls and indicators	59
Display	60
Symbols showing function key allocation.....	60
Monitoring and status LEDs.....	61
Startup phase and feeding energy into the grid.....	62
Startup phase.....	62
Feeding energy into the grid	62
Navigation at the menu level.....	63
Activate display backlighting	63
Automatic deactivation of display backlighting / change to display mode 'NOW'	63
Open menu level.....	63
The display modes.....	64
The display modes.....	64
Choosing a display mode.....	64
Overview of display values	65
Values in display mode 'NOW'	66
Choosing a display mode.....	66
Values in display mode 'NOW'	66
Values in display modes 'TODAY / YEAR / TOTAL'	68
Choose display mode 'TODAY / YEAR / TOTAL'	68
Values in display modes 'TODAY / YEAR / TOTAL'	68
The Setup menu	71
Initial setting.....	71
Accessing the setup menu.....	71
Move up and down the menu items.....	71
Menu items in the Set-up menu	72
Standby.....	72
Contrast.....	72
Backlighting.....	73

Language	73
Currency	73
CO2 factor.....	73
Yield	74
DATCOM	74
Device Info	75
Device Status.....	76
Time	76
Status LT.....	77
Grid Status	77
Fan test.....	77
Version.....	77
Setting and displaying the menu items	78
Setting the menu items, general	78
Exiting a menu item	79
Practical examples for setting and displaying menu items	79
Setting the display backlighting.....	79
Setting the currency and feed-in tariff.....	80
Setting the time and date	81
Switching the key lock on and off.....	83
General.....	83
Switching the key lock on and off.....	83

Troubleshooting and maintenance 85

Status diagnostics and troubleshooting	87
Displaying status codes	87
Total failure of the display	87
Class 1 status codes	87
Class 3 status codes	89
Class 4 status codes	91
Class 5 status codes	96
Class 7 status codes	98
Class 10 - 12 status codes.....	101
Customer service	101
Maintenance	102
Safety.....	102
Maintenance guidelines	102
Replacement of components	102
Opening the inverter for maintenance work	102
Operation in environments subject to heavy accumulations of dust.....	103
Replacing fuses	104
Safety.....	104
Replacing the reverse polarity protection fuse.....	104

Appendix 107

Technical data.....	109
Fronius Agilo 75.0-3.....	109
Fronius Agilo 100.0-3.....	110
Explanation of footnotes	111
Applicable standards and guidelines	112
CE mark.....	112
Parallel operation of in-plant generation systems	112
Power failure	112
Warranty terms and conditions, and disposal	113
Fronius manufacturer's warranty	113
Disposal	113

Safety rules

Explanation of safety symbols



DANGER! indicates immediate and real danger. If it is not avoided, death or serious injury will result.



WARNING! indicates a potentially dangerous situation. Death or serious injury may result if appropriate precautions are not taken.



CAUTION! indicates a situation where damage or injury could occur. If it is not avoided, minor injury and/or damage to property may result.



NOTE! indicates a risk of flawed results and possible damage to the equipment.

IMPORTANT! indicates tips for correct operation and other particularly useful information. It does not indicate a potentially damaging or dangerous situation.

If you see any of the symbols depicted in the "Safety rules", special care is required.

General



The device is manufactured using state-of-the-art technology and according to recognised safety standards. If used incorrectly or misused, however, it can cause

- injury or death to the operator or a third party,
- damage to the device and other material assets belonging to the operating company,
- inefficient operation of the device.

All persons involved in commissioning, maintaining and servicing the device must

- be suitably qualified,
- have knowledge of and experience in dealing with electrical installations and
- read and follow these operating instructions carefully.

The operating instructions must always be at hand wherever the device is being used. In addition to the operating instructions, attention must also be paid to any generally applicable and local regulations regarding accident prevention and environmental protection.

All safety and danger notices on the device

- must be kept in a legible state
- must not be damaged/marked
- must not be removed
- must not be covered, pasted or painted over.

For the location of the safety and danger notices on the device, refer to the section headed "General remarks" in the operating instructions for the device.

Before switching on the device, rectify any malfunctions that could compromise safety.

Your personal safety is at stake!

Proper use



The device is to be used exclusively for its intended purpose.

Any use above and beyond this purpose is deemed improper. The manufacturer shall not be liable for any damage resulting from such improper use.

Proper use also includes:

- carefully reading and obeying all the instructions and all the safety and danger notices in the operating instructions
- performing all stipulated inspection and servicing work
- installation as specified in the operating instructions

The following guidelines should also be applied where relevant:

- Regulations of the company providing the mains power supply
- Instructions from the PV module manufacturer

Environmental conditions



Operation or storage of the device outside the stipulated area will be deemed as "not in accordance with the intended purpose". The manufacturer shall not be held liable for any damage arising from such usage.

For exact information on permitted environmental conditions, please refer to the "Technical data" in the operating instructions.

Qualified service engineers



The servicing information contained in these operating instructions is intended only for the use of qualified service engineers. An electric shock can be fatal. Do not perform any actions other than those described in the documentation. This applies even if you are qualified to do so.



All cables and leads must be secure, undamaged, insulated and adequately dimensioned. Loose connections, scorched, damaged or inadequately dimensioned cables and leads must be immediately repaired by authorised personnel.



Maintenance and repair work must only be carried out by authorised personnel.

It is impossible to guarantee that bought-in parts are designed and manufactured to meet the demands made of them, or that they satisfy safety requirements. Use only original spare parts (also applies to standard parts).

Do not carry out any modifications, alterations, etc. to the device without the manufacturer's consent.

Components that are not in perfect condition must be changed immediately.

Safety measures at the installation location

When installing devices with openings for cooling air, ensure that the cooling air can enter and exit unhindered through the air ducts. Only operate the charger in accordance with the degree of protection shown on the rating plate.

Noise emission values



The inverter generates a maximum sound power level of < 80 dB(A) (ref. 1 pW) when operating under full load in accordance with IEC 62109-1:2010.

The device is cooled as quietly as possible with the aid of an electronic temperature control system, and depends on the amount of converted power, the ambient temperature, the level of soiling of the device, etc.

It is not possible to provide a workplace-related emission value for this device because the actual sound pressure level is heavily influenced by the installation situation, the power quality, the surrounding walls and the properties of the room in general.

EMC Device Classifications



Devices in emission class A:

- Are only designed for use in industrial settings
- Can cause line-bound and radiated interference in other areas

Devices in emission class B:

- Satisfy the emissions criteria for residential and industrial areas. This is also true for residential areas in which the energy is supplied from the public low-voltage mains.

EMC device classification as per the rating plate or technical data.

EMC measures



In certain cases, even though a device complies with the standard limit values for emissions, it may affect the application area for which it was designed (e.g. when there is sensitive equipment at the same location, or if the site where the device is installed is close to either radio or television receivers). If this is the case, then the operator is obliged to take appropriate action to rectify the situation.

Mains connection

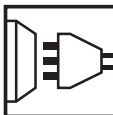

High-performance devices (> 16 A) can affect the voltage quality on the mains network because they can feed powerful current into the main supply.

This may affect a number of types of device in terms of:

- connection restrictions
- criteria with regard to the maximum permissible mains impedance *)
- criteria with regard to the minimum short-circuit power requirement *)

*) at the interface with the public mains supply

see Technical Data

In this case, the plant operator or the person using the device should check whether or not the device is allowed to be connected, where appropriate through discussion with the power supply company.

Electrical installations



Electrical installations must only be set up set up to the relevant national and local standards and regulations.

Protective measures against ESD



Danger of damage to electrical components from electrical discharge. Suitable measures should be taken to protect against ESD when replacing and installing components.

Safety measures in normal operation



Only operate the device if all safety devices are fully functional. If the safety devices are not fully functional, there is a risk of

- injury or death to the operator or a third party,
- damage to the device and other material assets belonging to the operator,
- inefficient operation of the device.

Any safety devices that are not functioning properly must be repaired by a suitably qualified engineer before the device is switched on.

Never bypass or disable safety devices.

Safety symbol



Devices with the CE mark satisfy the essential requirements of the low-voltage and electromagnetic compatibility directives. Further details can be found in the appendix or the section headed "Technical data" in your documentation.

Disposal



To comply with the European Directive 2002/96/EC on Waste Electrical and Electronic Equipment and its implementation as national law, electrical equipment that has reached the end of its life must be collected separately and returned to an approved recycling facility. Any device that you no longer require must either be returned to your dealer or given to one of the approved collection and recycling facilities in your area. Ignoring this European Directive may have potentially adverse effects on the environment and your health!

Data protection

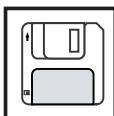

The user is responsible for the safekeeping of any changes made to the factory settings. The manufacturer accepts no liability for any deleted personal settings.

Copyright



Copyright of these operating instructions remains with the manufacturer.

The text and illustrations are all technically correct at the time of printing. We reserve the right to make changes. The contents of the operating instructions shall not provide the basis for any claims whatsoever on the part of the purchaser. If you have any suggestions for improvement, or can point out any mistakes that you have found in the instructions, we will be most grateful for your comments.

General information

Protection of people and equipment

Safety



WARNING! If the equipment is used or tasks are carried out incorrectly, serious injury or damage may result. Commissioning of the inverter may only be carried out by trained personnel in accordance with the technical regulations. It is essential that you read the "Safety Regulations" chapter before commissioning the equipment or carrying out maintenance work.

Protection of people and equipment

The inverter is constructed and operated in the safest possible way, both in terms of installation and operation.

The inverter fulfils the role of protecting people and equipment:

- a) through galvanic (electrical) isolation
 - b) by monitoring the grid
-

Galvanic (electrical) isolation

The inverter has a 50/60 Hz three-phase transformer that provides electrical isolation between the DC side and the grid, thus guaranteeing the highest possible levels of safety.

Monitoring the grid

In the event of abnormal grid conditions, the inverter shuts down immediately according to national standards and guidelines and stops feeding energy into the grid (e.g. in the event of grid disconnection, interrupts, etc.)

Grid monitoring is carried out by:

- monitoring the voltage
- monitoring the frequency
- using over/undervoltage relays (option, depends on country setup)
- monitoring the stand alone situation

Warning notices on the device

There are warning notices and safety symbols on and in the inverter. These warning notices and safety symbols must not be removed or painted over. They warn against operating the device incorrectly, as this may result in serious injury and damage.

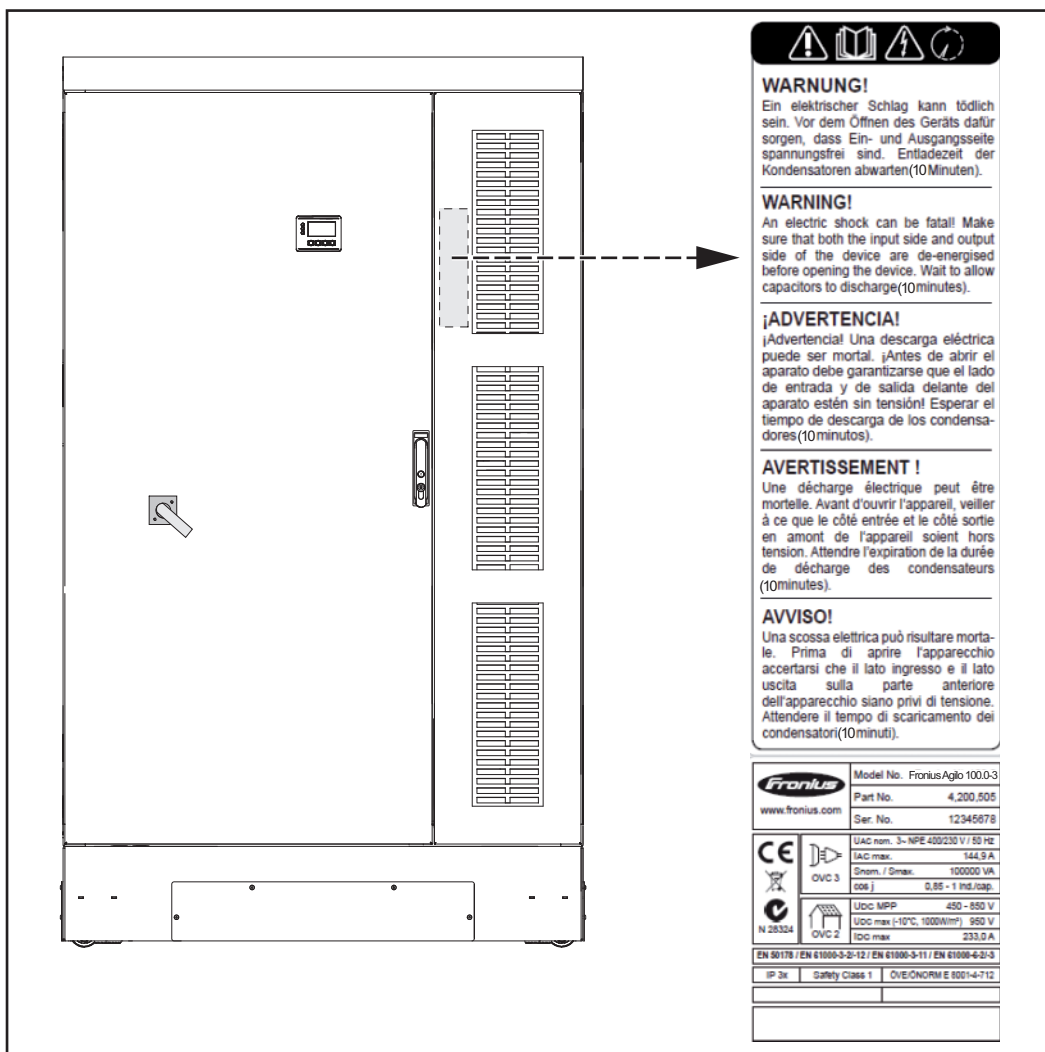

Safety symbols:



Risk of serious injury and damage due to incorrect operation



Do not use the functions described here until you have fully read and understood the following documents:

- these operating instructions
- all the operating instructions for the system components of the photovoltaic system, especially the safety rules



Dangerous electrical voltage



Discharging of the energy storage device is time-controlled

Text of the warning notices:

WARNING!

An electric shock can be fatal. Make sure that both the input side and output side of the device are de-energised before opening the device. Wait for the capacitors to discharge (10 minutes).

Proper use

Proper use

The solar inverter is intended exclusively to convert direct current from solar modules into alternating current and to feed this into the public grid.

Utilisation not in accordance with the intended purpose comprises:

- utilisation for any other purpose or in any other manner
- making any modifications to the inverter that have not been expressly approved by Fronius
- the installation of parts that are not distributed or expressly approved by Fronius.

Fronius shall not be liable for any damage resulting from such action.

No warranty claims will be entertained.

Proper use also includes:

- complying with all the instructions in the operating instructions
 - performing all stipulated inspection and maintenance work
-

Application area

The inverter has been developed exclusively for use in grid-connected photovoltaic systems; generating energy independently of the public grid is not possible.

Regulations governing the photovoltaic system

The inverter is designed to be connected and used exclusively in conjunction with solar modules.

Use of the inverter with other DC generators (e.g. wind generators) is not permitted

When designing the photovoltaic system, ensure that all its components are operated within their permitted operating ranges at all times.

Observe all the measures recommended by the solar module manufacturer to ensure the lasting maintenance of the properties of the solar module.

Functional principle

Functional principle The inverter operates fully automatically. The control module starts monitoring the grid voltage and frequency as soon as the solar modules produce enough energy after sunrise. When insolation has reached a sufficient level, the solar inverter will start to feed energy into the grid.

The inverter works in a way that ensures the maximum power possible is obtained from the solar modules.

This is known as "Maximum Power Point Tracking" (MPPT).

As soon after dusk as the power available to feed into the mains falls below a sufficient level, the inverter disconnects from the mains supply. It retains all its settings and stored data.

Cooling of the inverter through forced-air ventilation Cooling of the inverter is performed by a forced-air ventilation system via a temperature-controlled radial fan. Air is sucked in from the front and fed, via a sealed duct, through the electronics compartment, before passing directly over the inductors and dissipating upwards.

The sealed air duct prevents the electronics compartment from coming into contact with the ambient air. This approach largely prevents any contamination of the electronics compartment.

The speed of the fan and temperature of the intake air are monitored.

The variable-speed, ball-bearing mounted fans in the inverter permit the following:

- optimum cooling of the inverter
 - a higher level of efficiency
 - cooler parts, therefore a longer service life
 - lowest-possible energy consumption and noise levels
-

Power derating To protect the inverter if adequate heat dissipation is not possible, even with the fans running at full speed (e.g. when installed in containers without proper heat dissipation measures), the operation known as power derating takes place above an ambient temperature of approximately 40 °C.

Power derating briefly reduces the power of the inverter to prevent the temperature exceeding its permitted limit.

The inverter remains operational for as long as possible without stopping.

Solar module grounding The inverter is designed for use with non-grounded solar modules and those grounded on the negative pole. Grounding of the solar module on the negative pole is carried out inside the inverter via a fuse holder equipped with a corresponding fuse as required.

The inverter in a photovoltaic system

General

The solar inverter acts as a highly sophisticated link between the solar modules and the public grid.

Tasks

The main tasks of the inverter are as follows:

- converting DC to AC current
 - fully automatic operational management
 - display function and data communication
-

Converting DC to AC current

The inverter converts the direct current created in the solar modules into alternating current. This alternating current is fed synchronously with the grid voltage into the in-house network or the public grid.

IMPORTANT! The inverter has been developed exclusively for use in grid-connected photovoltaic systems; generating energy independently of the public grid is not possible.

Display function and data communication

The display on the inverter acts as the interface between the inverter and the user. The display design is oriented towards simple operation and to making the system data available at all times.

The inverter has a range of basic functions for logging minimum and maximum values on a daily and total basis. The values are output on the display.

An extensive selection of data communication elements opens up numerous recording and visualisation options.

System add-on

The inverter is able to accommodate a wide variety of system add-ons, such as:

- a datalogger, to enable a PC to record and manage data from a photovoltaic system
- various large-format displays
- interfaces to transfer system data in a freely accessible format
- devices to combine and monitor solar module strings

The inverter is not designed to be used with optional plug-in cards. System add-ons must be installed in a separate housing.

Description of the device

Outside of inverter

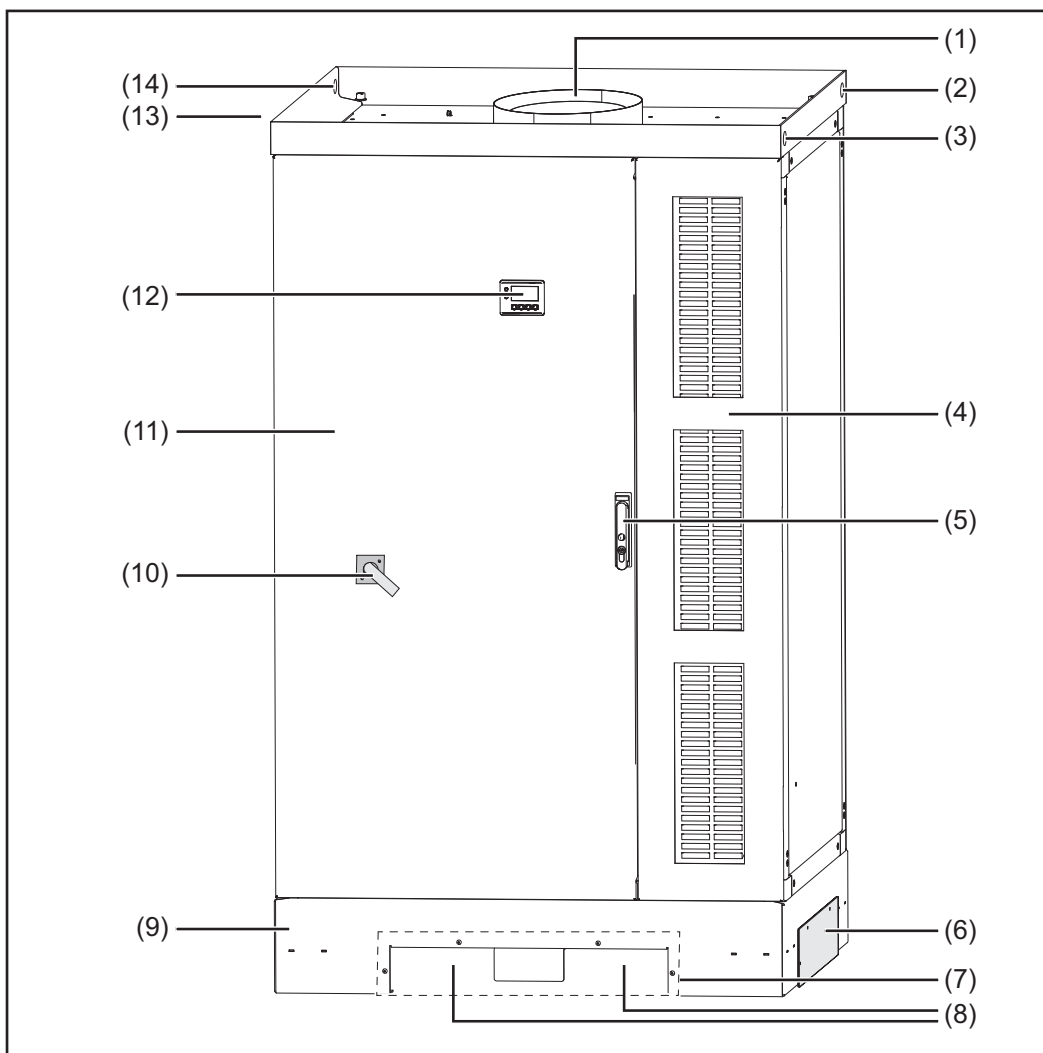

Item	Description
(1)	Outlet air opening, diameter 315 mm
(2)	Lifting eye for crane transport
(3)	Lifting eye for crane transport
(4)	Air inlet grille
(5)	Door handle (lockable)
(6)	Right side panel (opposite: left side panel)
(7)	Front cover (opposite: rear cover)
(8)	Forklift truck receptacle
(9)	Base
(10)	DC main switch, lockable when switched off
IMPORTANT! The door cannot be opened when the DC main switch is switched on.	
(11)	Door
(12)	Control elements (display, buttons, monitoring and status LEDs)

Item	Description
(13)	Lifting eye for crane transport
(14)	Lifting eye for crane transport

Inside the inverter

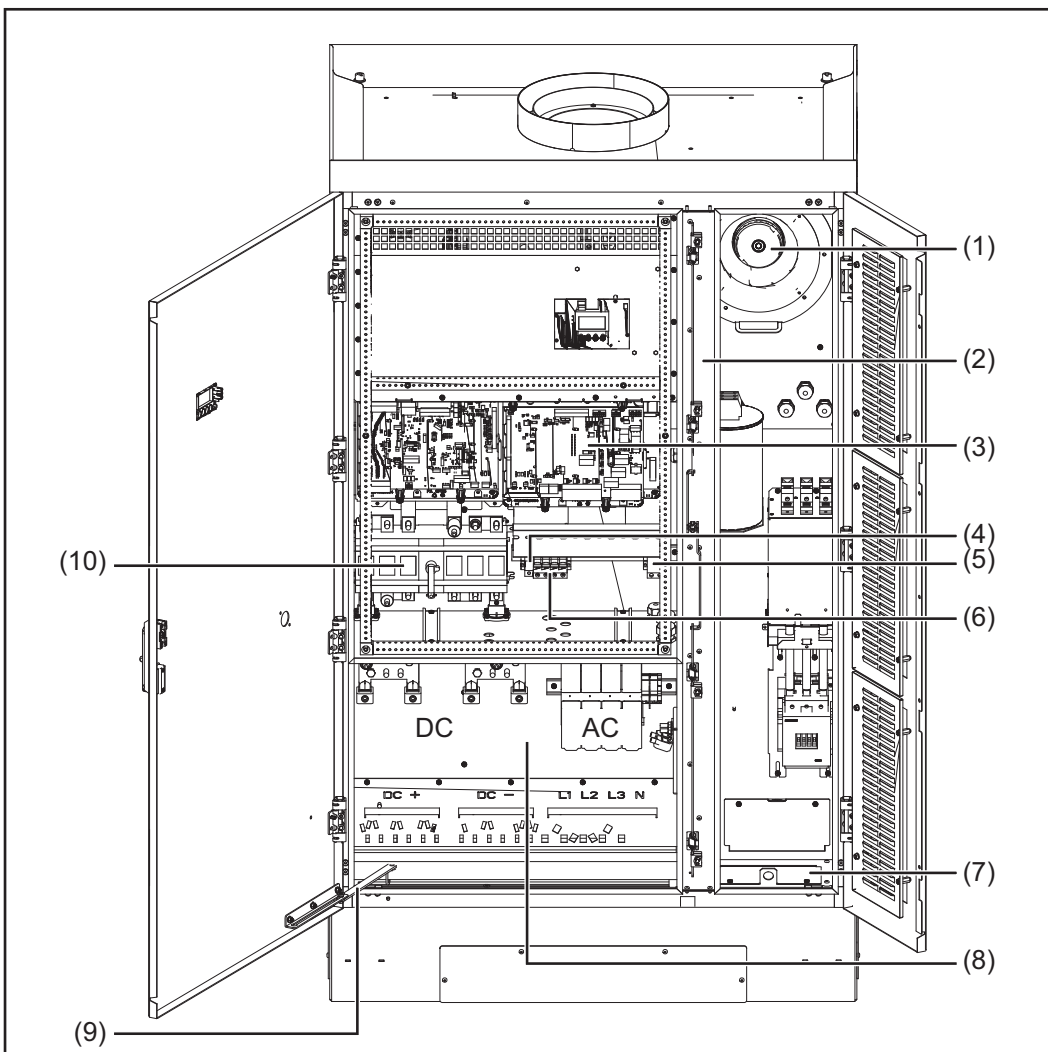

Item	Description
(1)	Fan
(2)	Holes for air inlet grille fastening screws (5x)
(3)	Data communication area
(4)	Fuse holder for operation with solar modules grounded on the negative pole: DC- to PE
(5)	2-pin automatic circuit breaker to protect the AC power supply
(6)	4-pin automatic circuit breaker to protect the measuring lines on the grid side
(7)	Revision cover
(8)	Connection compartment
(9)	Door catch
(10)	DC main switch

The DC main switch shaft is not fitted when the inverter is delivered.

Connection compartment

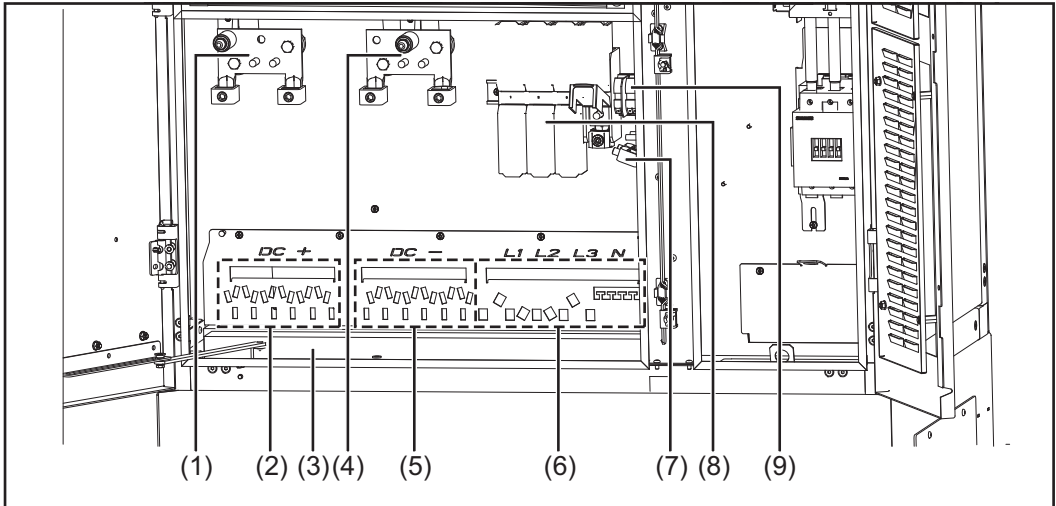

Item	Description
(1)	DC+ connections
(2)	Openings for attaching the strain-relief clamps* for the DC+ cable
(3)	Cable input opening with sliding cover and seal
(4)	DC- connections
(5)	Openings for attaching the strain-relief clamps* for the DC- cable
(6)	Openings for attaching the strain-relief clamps* for the AC cable
(7)	Grounding terminal for AC cable
(8)	Mains connections L1, L2, L3 and N with connection cover
(9)	AC power supply

* The strain-relief clamps and other installation and connection accessories are part of the scope of supply of the inverter.

Data communication area

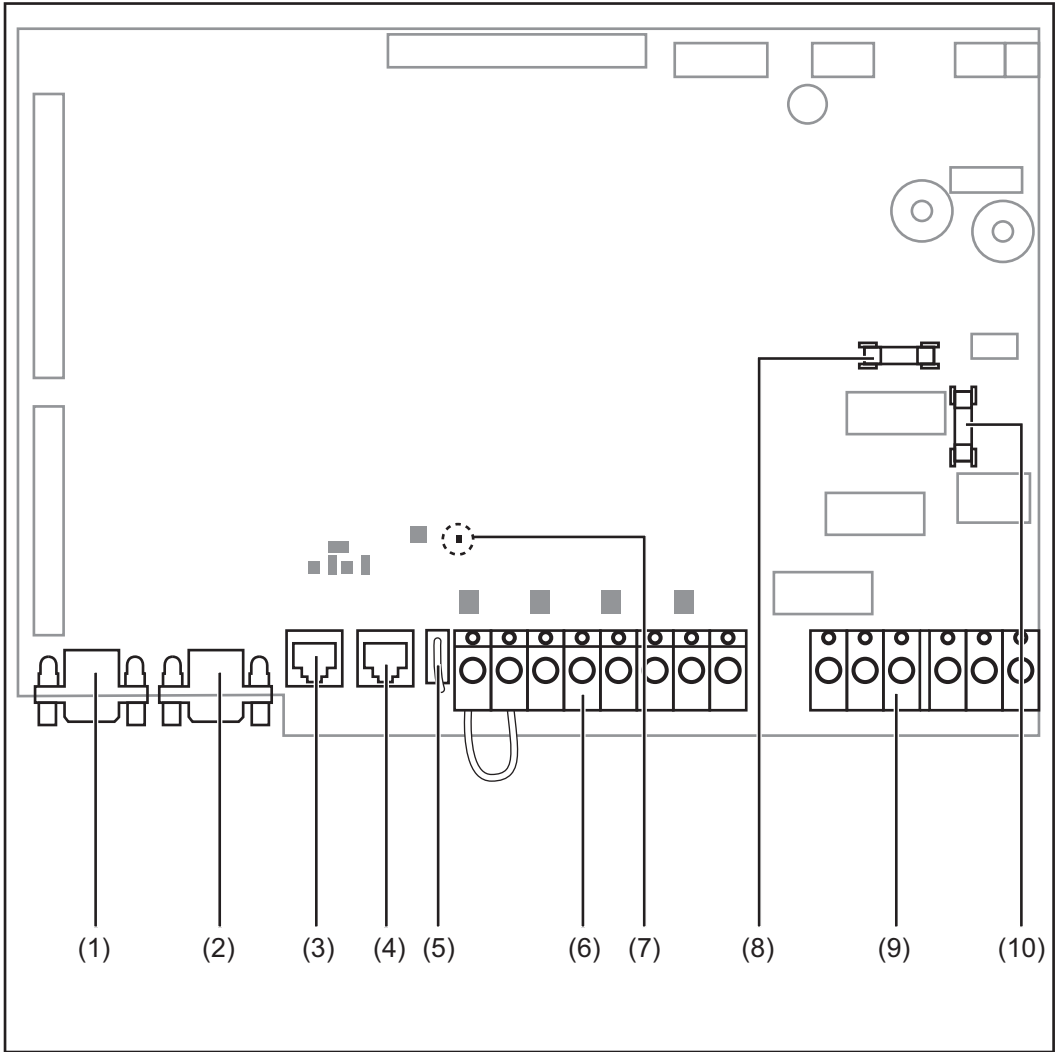

Item	Description
(1)	for future use
(2)	
(3)	Solar Net IN connection socket 'Fronius Solar Net' input, for connecting to other DATCOM components (e.g. inverter, sensor box, etc.)
(4)	Solar Net OUT connection socket 'Fronius Solar Net' output, for connecting to other DATCOM components (e.g. inverter, sensor box, etc.)
(5)	VSR connection socket for connecting an external measuring and monitoring relay
<p>The contact must be potential-free. Contact rating 24 V / 10 mA</p>	

Item	Description
------	-------------

(6) NO/alarm terminals

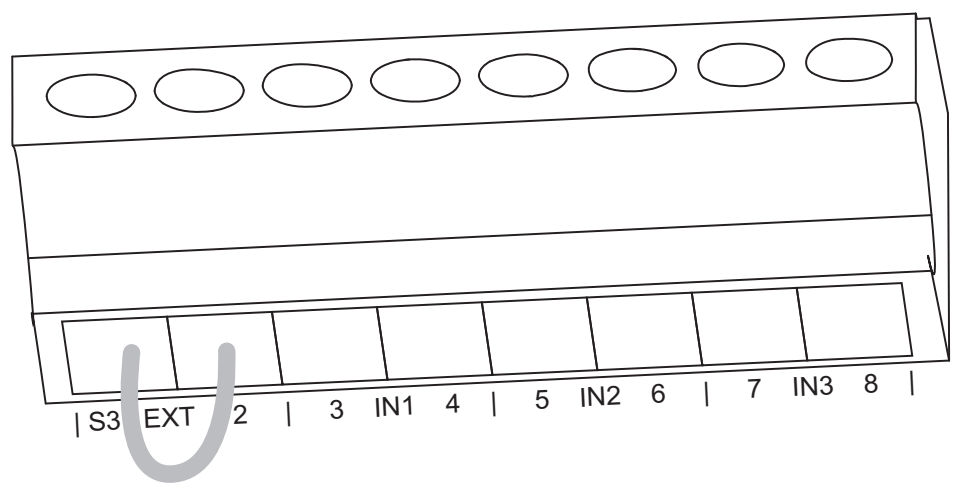

- S3 - 2 EXT
for connecting an external NO contact, e.g. to isolate the device from the grid voltage using an AC contactor;
connected using bracket when delivered.
- 3 - 4 IN1
for connecting and evaluating a floating alarm contact
- 5 - 6 IN2
for connecting and evaluating a floating alarm contact
- 7 - 8 IN3
for connecting and evaluating a floating alarm contact

The contacts must be potential-free.

 Contact rating 24 V / 10 mA
 Cable cross-section: 0.5 - 6 mm²
 Tightening torque of terminals: 0.8 - 1.6 Nm

(7)	'Solar Net' LED shows the current status of the Fronius Solar Net
(8)	Fuse F1 for switched-mode power supply, 4 A slow-blow

Item	Description
(9)	Relay output terminals

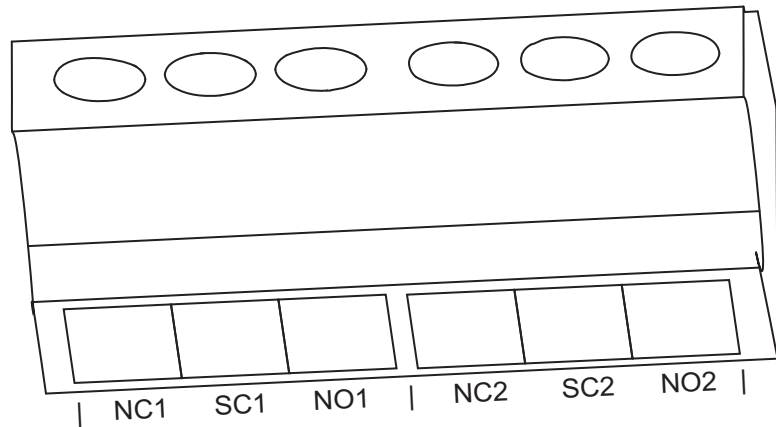

NC1 NC for relay contact 1
 SC1 Relay contact 1
 NO1 NO for relay contact 1

NC2 NC for relay contact 2
 SC2 Relay contact 2
 NO2 NO for relay contact 2

Cable cross-section: 0.5 - 6 mm²
 Tightening torque of terminals: 0.8 - 1.6 Nm
 Max. continuous current: 16 A
 Switching load: 500 mW (10 V / 5 mA)
 Switching capacity: 16 A / 250 V (AC1) and 16 A / 30 V (DC1)
 The relay outputs are not protected.

Relay contacts can be assigned different functions in the Basic service menu. The access code 22742 must be entered to access the Basic service menu:

- Press the 'Menu' key
- Select 'Setup' mode
- Press the unassigned 'Esc' button five times
- Enter the access code 22742
- Select the 'Switch contact 1' or 'Switch contact 2' parameter
- Set the desired relay contact function

(10)	F2 fuse, 4 A slow-blow
------	------------------------

Possible relay contact functions

Function	Switch contact activation criterion ¹⁾	Switch contact deactivation criterion ²⁾	Description
Off	-	Permanently OFF	Function switched off
On	Permanently ON	-	Test function for NO/ alarm contact
AC Open	AC contactor is open	AC contactor is closed	No contactor error signal or AC grid
Fan On	Cabinet fan in operation	Cabinet fan not working	External ventilation / air conditioning can be activated
> 40 °C	max. internal temperature ≥ 40 °C	max. internal temperature ≤ 30 °C	
> 50 °C	max. internal temperature ≥ 50 °C	max. internal temperature ≤ 40 °C	
Sig. Rel.	NO/alarm contact trips	Error confirmation at the touch of a button / by Solar Net command	Status indicator / relay contact switches
Running	Inverter feeding energy into the grid	Inverter not feeding energy into the grid	Control of powered non-return valve
Warning	Defined warning status codes	Error confirmation at the touch of a button / by Solar Net command	NO/alarm contact activation, when certain warning status codes occur at a specific frequency according to the 'Error-Counter' Service menu
Error	Defined error status codes	Error confirmation at the touch of a button / by Solar Net command	NO/alarm contact activation, when certain error status codes occur at a specific frequency according to the 'Error-Counter' Service menu

1) Activation = the NC for the relay contact opens, the NO closes

2) Deactivation = the NC for the relay contact closes, the NO opens

Data communication and Solar Net

Solar Net and data interface

Fronius Solar Net was developed to make system add-ons flexible and capable of being used in a wide variety of different applications. Fronius Solar Net is a data network that enables more than one inverter to be linked up using system add-ons.

It is a bus system. A single cable is all that is required for one or more inverters to communicate with all the system add-ons.

Fronius Solar Net automatically recognises a wide variety of system add-ons.

In order to distinguish between several identical system add-ons, each one must be assigned a unique number.

Similarly, every inverter on the Fronius Solar Net must be assigned a unique number. Refer to the section entitled 'The Setup-Menu' for instructions on how to assign a unique number.

More detailed information on the individual system add-ons can be found in the relevant operating instructions or on the internet at <http://www.fronius.com>.

More detailed information on cabling DATCOM components can be found at <http://www.fronius.com> - Solar Electronics / Info & Support / Document downloads / Operating instructions / System monitoring / Fronius DATCOM cabling guide.

Overcurrent and undervoltage cut-out

The data communications electronics have a cut-out function that interrupts the power supply in the Fronius Solar Net:

- in response to overcurrent, e.g. in the event of a short circuit
- in response to undervoltage

The overcurrent and undervoltage cut-out does not depend on the current flow direction. If the Fronius Solar Net measures a current flow > 3 A or a voltage < 6.5 V, the power supply in the Fronius Solar Net is interrupted.

The power supply is restored automatically.

Description of the 'Fronius Solar Net' LED

The 'Fronius Solar Net' LED is on:

the power supply for data communication within the Fronius Solar Net is OK

The 'Fronius Solar Net' LED is off:

data communication error in the Fronius Solar Net

- Overcurrent (current flow > 3 A, e.g. resulting from a short circuit in the Fronius Solar Net)
- Undervoltage (not a short circuit, voltage in Fronius Solar Net < 6.5 V, e.g. if there are too many DATCOM components on the Fronius Solar Net and not enough electrical power is available)

In this case, power for the DATCOM components must be supplied by connecting an external power unit to one of the DATCOM components.

To detect the presence of an undervoltage, check some of the other DATCOM components as required.

The 'Fronius Solar Net' LED flashes briefly every 5 seconds:

following a shutdown as the result of an overcurrent or undervoltage, the inverter attempts to restore the power supply to the Fronius Solar Net every 5 seconds while the fault persists.

Once the fault is rectified, power to the Fronius Solar Net will be restored within 5 seconds.

Example

Recording and archiving of inverter data using Fronius Datalogger Web, data output on external display:

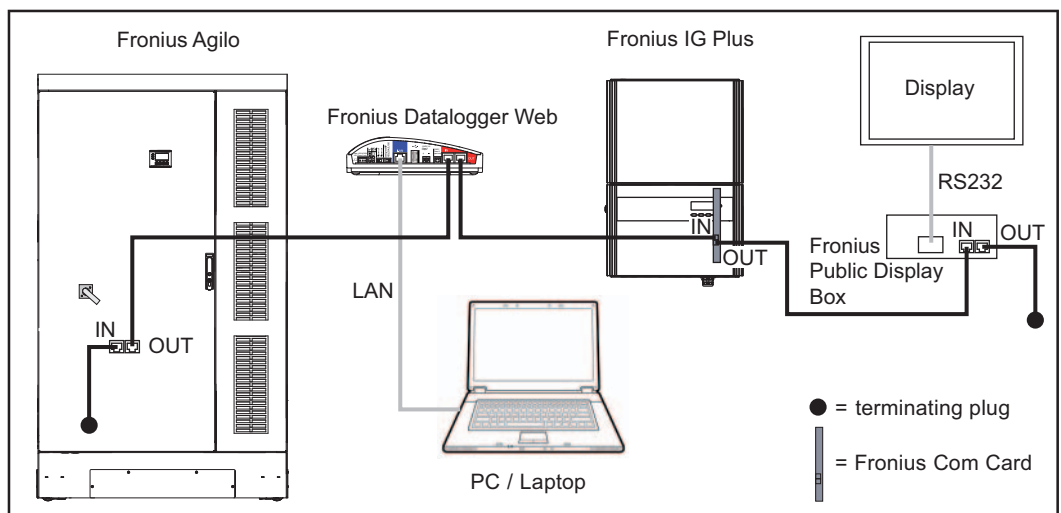

Captions:

Fronius Solar Net data network with

- 1 Fronius Agilo
- 1 Fronius IG Plus with a 'Fronius Com Card'
- 1 Fronius Datalogger Web with LAN interface for connecting to a PC/laptop
- 1 Fronius Public Display Box
- 1 external display

Communication between the individual components themselves is handled by Fronius Solar Net.

Installation and commissioning

Choice of location

General comments regarding choice of location

The IP 30 degree of protection of the inverter dictates that it be installed exclusively in enclosed spaces or containers.

The inverter must be completely covered by a building or structure in order to protect it from rain, snow, wind-borne dust, fungal attack, radiation on cold nights, etc.

The building or structure must satisfy the requirements in terms of temperature, humidity and air filtering. Condensation is not anticipated.

The following points must also be taken into account in the choice of location:

- the cabling into the inverter,
- the specified bending radii of the cables,
- adequate bearing capacity per m² of floor for the inverter weight of 834 kg.

IMPORTANT! The adequate bearing capacity of the floor must be ensured before introducing and setting up the inverter!

Cabling into the inverter

The AC cable, DC cable and the data communications cable, if required, can be fed into the inverter-as follows:

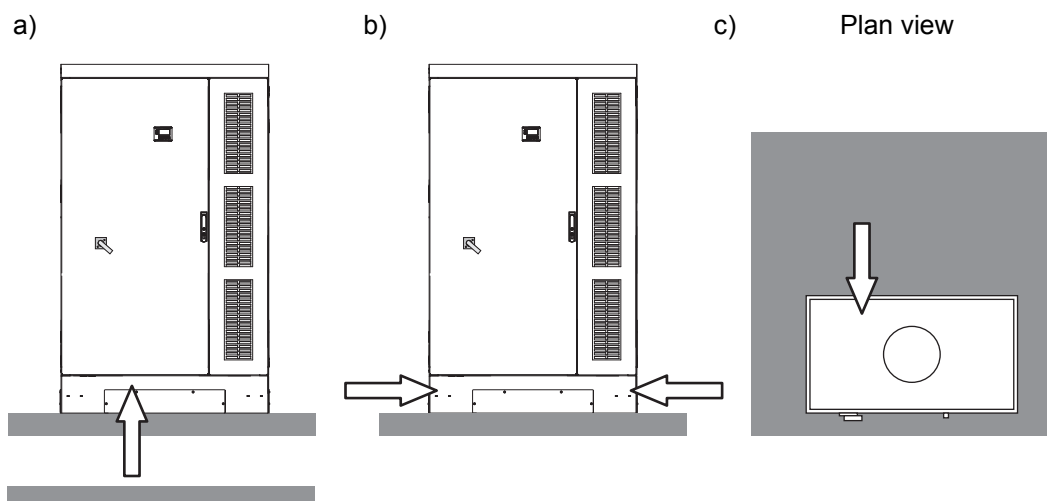

- a) from below (e.g. via a cable duct or a false floor)
- b) from the side through the base
- c) from the rear through the base

Feeding the cabling through the base is only possible for cables with a cross-section of max. 120 mm².

IMPORTANT! If AC cables, DC cables and data communication cables are fed together into the inverter, ensure adequate insulation is provided between the AC/DC cables and the data communication cables.

Criteria influencing choice of location

Place on a solid, even, level and fire-resistant surface only.

Max. ambient temperatures: -20 °C; +50 °C

Can be used at altitudes of up to 2000 m

Maintain the following lateral clearances between the inverter and a wall:

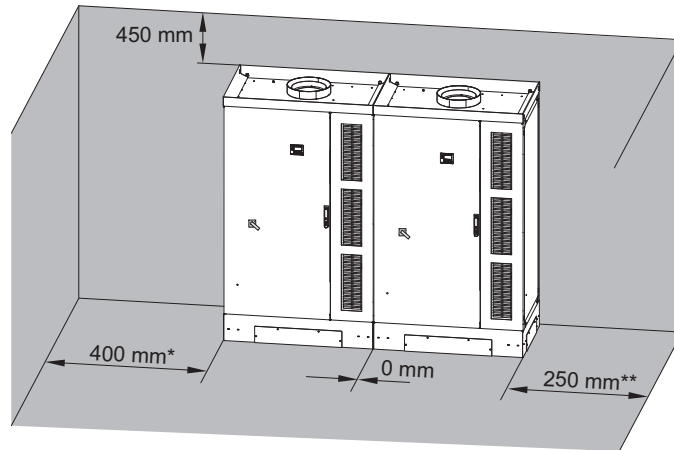

* Wall - left side of inverter:

min. 400 mm (to permit the door to be opened fully and its catch to be latched)

min. 50 mm (to open the door 90°, door catch not latched)

** Wall - right side of inverter:

min. 250 mm (to permit the air inlet grille to be opened fully)

Two or more inverters can be placed side-by-side or back-to-back.

The clearance between the top of the inverter and the ceiling must be at least 450 mm in order to prevent air from accumulating.

If the clearance is less than this, install an extractor.

The airflow within the inverter is from the front to the top (cold air taken in at the front, hot air emitted out of the top).

If the inverter is installed in an enclosed space, then forced-air ventilation must be provided to ensure adequate heat dissipation.

Unsuitable locations

Do not install the inverter:

- in living areas
- in rooms where the device will be directly exposed to water
- in rooms subject to heavy accumulations of dust
- in rooms in which a heavy build-up of dust containing conductive particles (e.g. iron chips) is likely
- in rooms containing caustic vapours, acids or salts
- in places where there is an increased risk of damage from farm animals (horses, cattle, sheep, pigs, etc.)
- in stables or adjoining areas
- in storage areas for hay, straw, chaff, animal feed, fertilisers, etc.
- in storage or processing areas for fruit, vegetables or winegrowing products
- in rooms used in the preparation of grain, green fodder or animal feeds
- in greenhouses

Transport

Transport

The inverter weighs approx. 850 kg and can be transported as follows:

- by its lifting eyes, e.g. using a crane or other suitable lifting gear and tackle
- by its forklift truck receptacle, e.g. using a forklift truck, lift truck or crane in conjunction with pallet forks
- manually using the heavy-duty castors attached to the inverter

Transporting by its lifting eyes using a crane



WARNING! Falling equipment can cause serious or even fatal injury. When transporting the inverter using a crane

- always use all four of the lifting eyes provided for this purpose,
- the length of the lifting tackle (chain, rope, strap, etc.) must be chosen so that the angle between the lifting tackle and the horizontal is at least 60°.

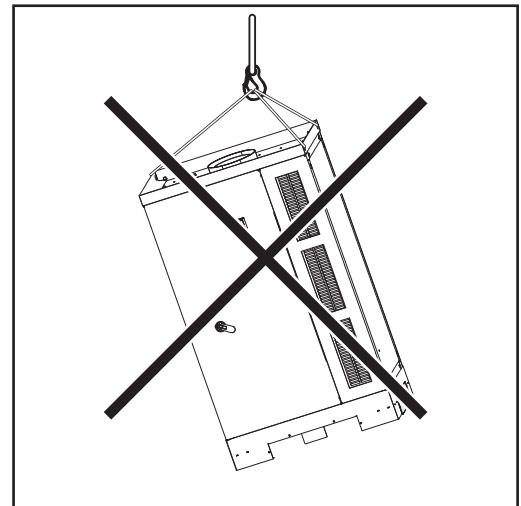
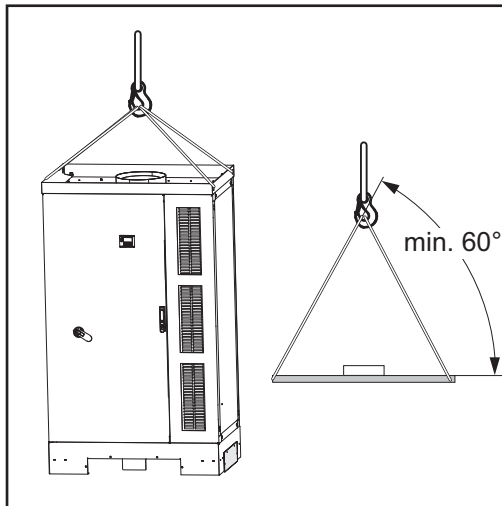

Transporting by crane using pallet fork



WARNING! Falling equipment can cause serious or even fatal injury. When transporting the inverter using a crane and pallet fork

- the pallet fork must have a headroom of at least 1900 mm
- always insert the pallet fork into the forklift truck receptacle
- always insert the pallet fork completely into the forklift truck receptacle
- secure the inverter to prevent it slipping off the pallet fork

Remove the front and rear cover from the base of the inverter before transporting it using a pallet fork, forklift truck or lift truck.

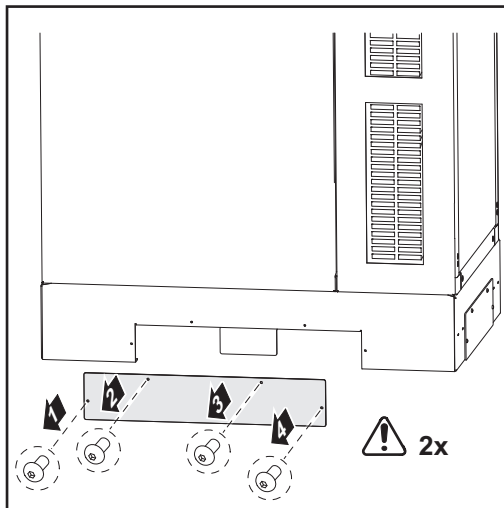

Transporting by forklift truck or lift truck



WARNING! Equipment that falls or topples over can cause serious or even fatal injury.

- always insert the fork into the forklift truck receptacle
- always insert the fork completely into the forklift truck receptacle
- secure the inverter to prevent it slipping off the fork or falling over
- avoid sudden changes in direction, braking or acceleration

Remove the front and rear cover from the base of the inverter before transporting it using a pallet fork, forklift truck or lift truck.

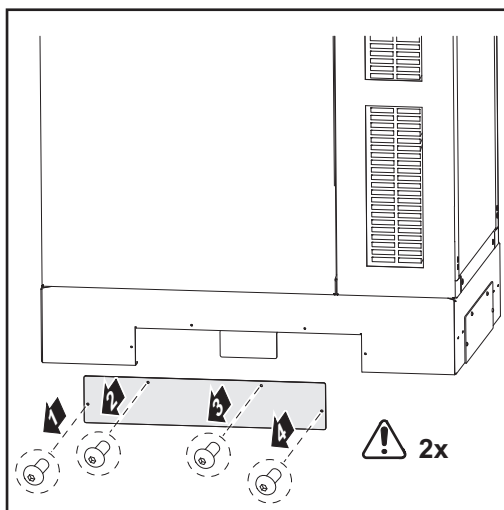

Manual transport

There are four heavy-duty castors on the underside of the inverter. If it is not possible to transport the inverter by crane or a forklift or lift truck, these heavy-duty castors will enable someone to push it over a flat surface. The heavy-duty castors are particularly suitable for positioning the inverter exactly and compensating for any slight unevenness.

Positioning the inverter

Prerequisites



WARNING! Equipment that falls or topples over can cause serious or even fatal injury.

- Place the inverter on a solid, level surface in such a way that it remains stable.
- Do not under any circumstances tip the inverter while it is being positioned.

Before positioning the inverter, clarify how the cables are going to be fed in.

If it is not going to be possible to feed any cables into the inverter once it has been positioned, all the AC, DC and data communication cables must, before the inverter is put in place,

- be dimensioned accordingly,
- protrude at least 650 mm out of the floor.



CAUTION! Risk of cable damage as a result of shearing or bending.

if any cables are protruding out of the floor, use a crane or forklift truck to lift the inverter over the cables and position the inverter in its desired location. Under no circumstances attempt to position the inverter using the heavy-duty castors.

Once the inverter has been positioned and the cables have been fed into it, any fine positional adjustments can then be made using the heavy-duty castors.

Positioning the inverter

IMPORTANT! Ensure that any covers which were removed previously are refitted before the inverter is moved to its final position (e.g. fit the rear cover before positioning the inverter up against a wall).

- 1 Transport the inverter to its location
- 2 Fit any covers that will no longer be accessible once the inverter is in its final position
- 3 Move the inverter manually into its final position using the heavy-duty castors



CAUTION! An inadequate ground conductor connection can cause serious injury or damage.

The screws on the air inlet grille and on the covers provide a suitable ground conductor connection for the housing; these screws must not under any circumstances be replaced by other screws that do not provide a reliable ground conductor connection.

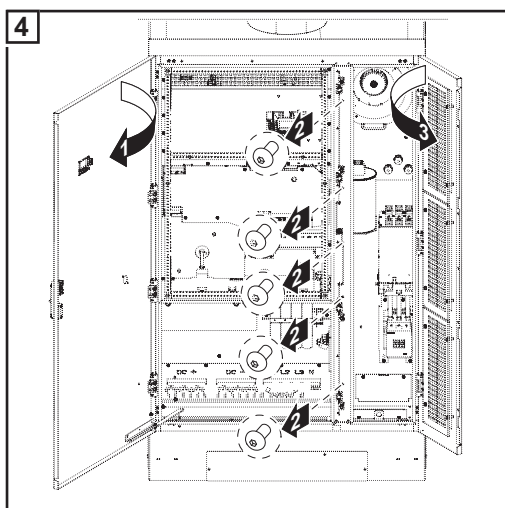

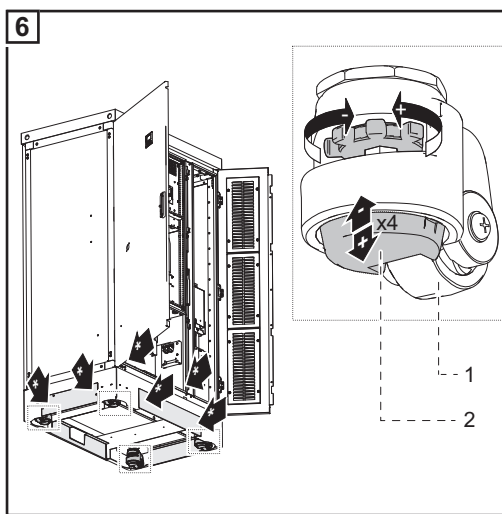
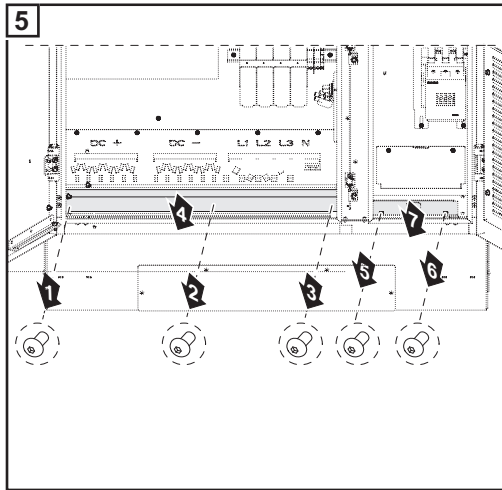

Fixing the heavy-duty castors

- (1) Castor
- (2) Rubber stopper

* Ways of accessing the heavy-duty castors on the underside of the inverter

Counter-clockwise:
unscrew rubber stopper

Clockwise:
screw in rubber stopper

IMPORTANT! Secure all 4 of the inverter's heavy-duty castors. Unscrew the rubber stopper beyond the castor.

To prevent any subsequent distortion of the doors of the inverter, ensure that the inverter is always absolutely level.

Any slight unevenness can be compensated for using the rubber stoppers.

Notes regarding the air supply and the connection of an exhaust duct

The air supply to the inverter must be at least 1200 m³/h (approx. 20 m³/min).

When connecting an exhaust duct, the back pressure it causes must not exceed 150 Pa. This results in a volumetric flow of about 15 m³/min.

Connecting the inverter to the public grid (AC)

Monitoring the grid

IMPORTANT! To provide the best possible grid monitoring, the resistance in the leads to the mains connections should be as low as possible.

Mains connections

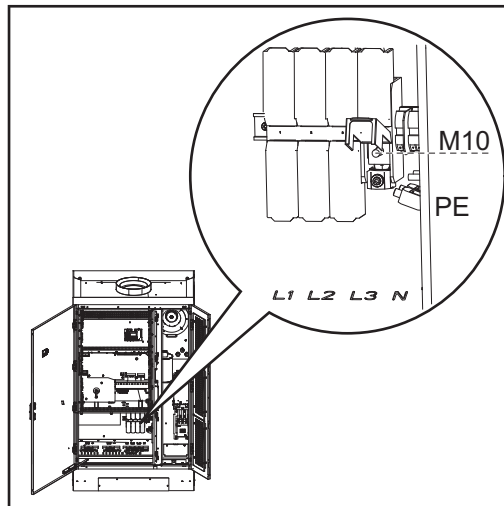

Legend:

L1	Phase conductor
L2	Phase conductor
L3	Phase conductor
N	Neutral conductor
PE	Ground conductor / grounding



NOTE! Ensure that the grid neutral conductor is grounded.

IMPORTANT! Only the following cables may be connected to V-type terminals:

- RE (round single-wire)
- RM (round multi-strand)
- SE (sector-shaped single-wire)
- SM (sector-shaped multi-strand)
- fine-core cables, in conjunction with ferrules only

Fine-core cables without ferrules may only be connected to the M10 threaded bolts of the mains connections using a suitable M10 cable lug; tightening torque = 18 Nm

Connecting aluminium cables

Aluminium cables can be connected to the mains connections.



NOTE! When connecting aluminium cables:

- observe national and international guidelines regarding the connection of aluminium cables
- follow the instructions of the cable manufacturer
- check every year that the cables are securely attached in accordance with the specified torque.

Max. cross-section of AC cables

The max. cross-section of the AC cables is 95 mm². The optimum bending radii inside the inverter are derived from this cable cross-section.

Safety



WARNING! An electric shock can be fatal. Danger due to grid voltage and DC voltage from solar modules.

- Make sure that both the AC side and the DC side of the inverter are de-energised before making any connections.
- Only an authorised electrical engineer is permitted to connect this equipment to the public grid.



CAUTION! Risk of damage to the inverter as the result of incorrectly tightened cable connections. Incorrectly tightened cable connections can cause heat damage to the inverter that may result in a fire. When connecting AC and DC cables, ensure that all the cables are tightened to the inverter terminals with the specified torque.

Connecting the inverter to the public grid



NOTE! Ensure that the phases are connected in the right order: L1, L2, L3, N and PE.

After connecting the phases, check the rotary field of the grid using a rotary field measuring device. The inverter is designed for a clockwise rotary field.

IMPORTANT!

Minimum cable cross section for the ground conductor PE:

10 mm² für Copper wire

16 mm² für Aluminium wire

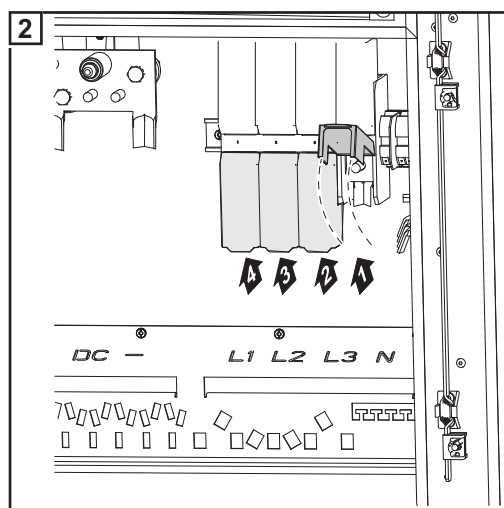
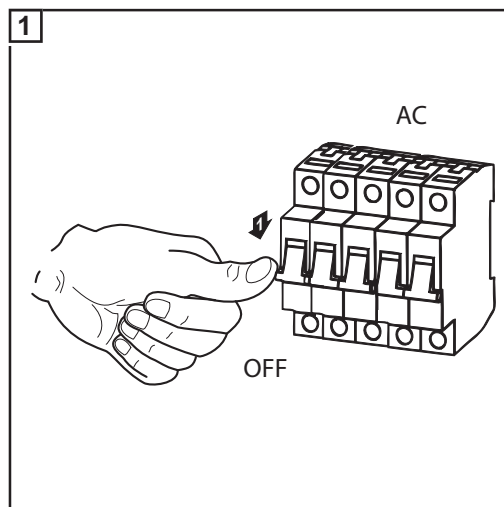

- Open the connection covers for the mains connections

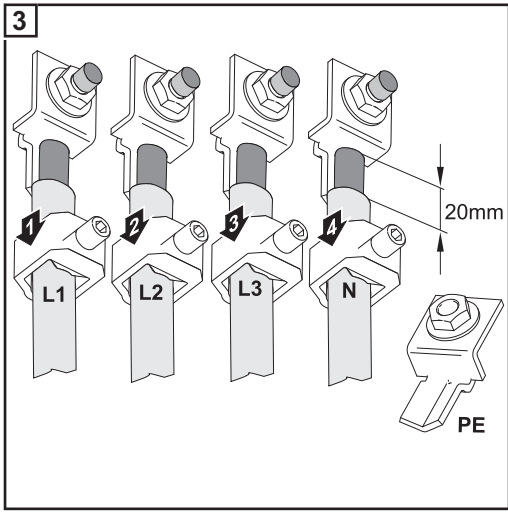

- Feed the AC cable into the inverter, observing the bending radii specified by the cable manufacturer
- Strip sheath from AC cable
- Strip at least 20 mm of wire from phase conductor L1 - L3, neutral conductor N and ground conductor PE
- Align phase conductors L1 - L3 and neutral conductor N with the mains connections according to the phase
- Align the ground conductor PE with the grounding terminal
- Push the AC terminal over the phase conductor, the neutral conductor and the ground conductor

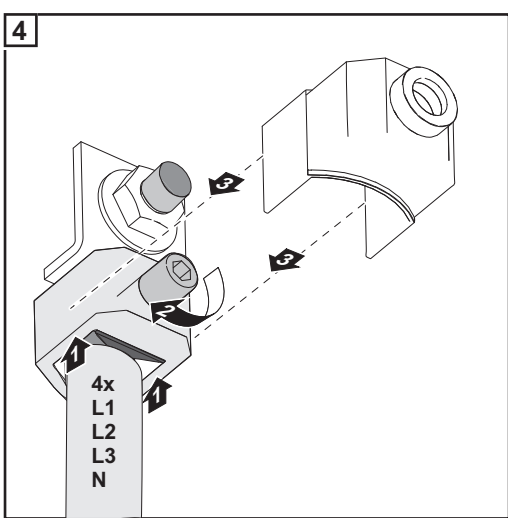

- Push the AC terminal up and over the mains connection and the bare end of the cable
 - Tighten the AC terminal:
5 mm Allen key
- Tightening torque = 12 Nm
- Place the insulation caps onto the mains connections
 - Repeat the process for phase conductors L2 and L3 and the neutral conductor N

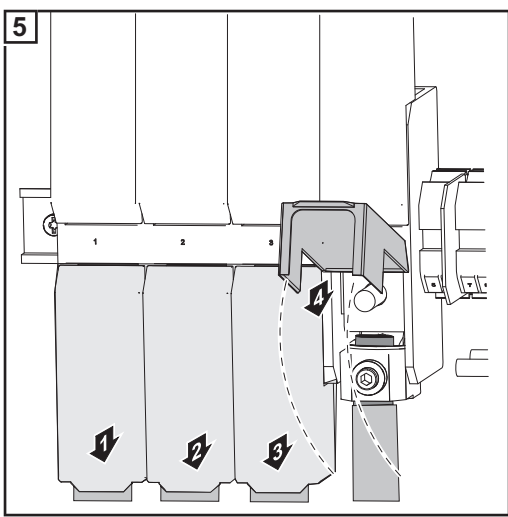

- Close the connection covers for the mains connections

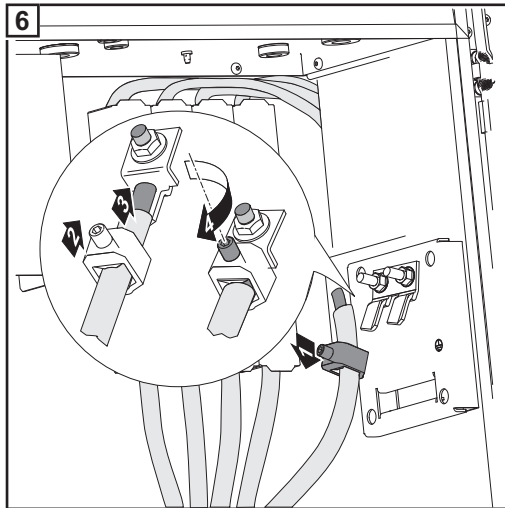

- Push the PE terminal up and over the grounding terminal and the bare end of the cable
- Tighten the PE terminal:
5 mm Allen key

Tightening torque = 12 Nm

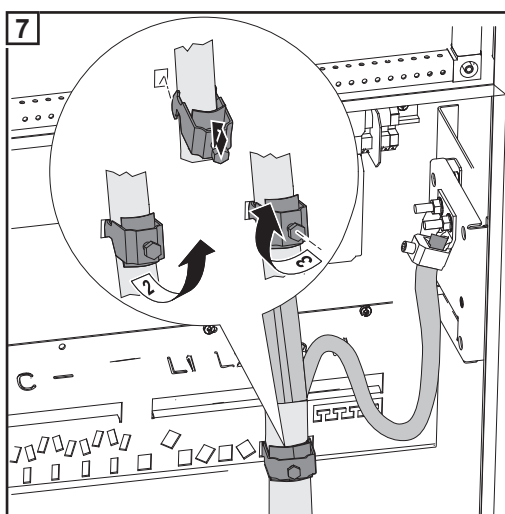

- Place the AC cable in the clamp of the strain-relief device
- Attach the clamps of the strain-relief device to the rail
- Secure the AC cable with the clamps of the strain-relief device



NOTE! Different openings are available on the rail for attaching the clamps of the strain-relief device, depending on the cable routing.

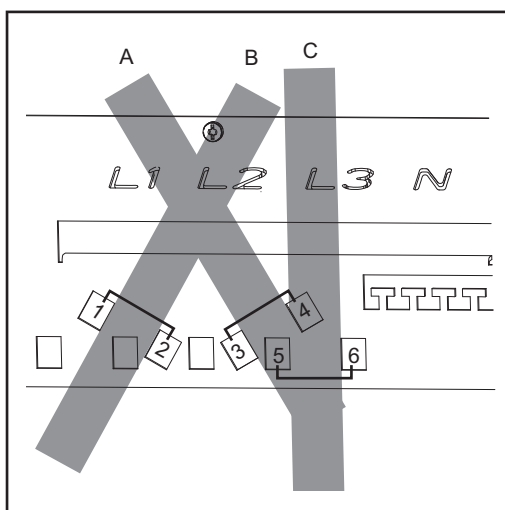

e.g.:

- A cable routed at an angle from the bottom right - attach the clamp for the strain-relief device to positions 3 and 4
- B cable routed at an angle from the bottom left - attach the clamp for the strain-relief device to positions 1 and 2
- C vertical cable routing - attach the clamp for the strain-relief device to positions 5 and 6

Connecting AC cables with a cable lug

Alternatively, an AC cable with a cable lug can be connected to the M10 threaded bolts on the mains connections in order to connect the AC cables to the V-type terminals.



NOTE! Ensure that the phases are connected in the right order: L1, L2, L3, N and PE.

After connecting the phases, check the rotary field of the grid using a rotary field measuring device. The inverter is designed for a clockwise rotary field.

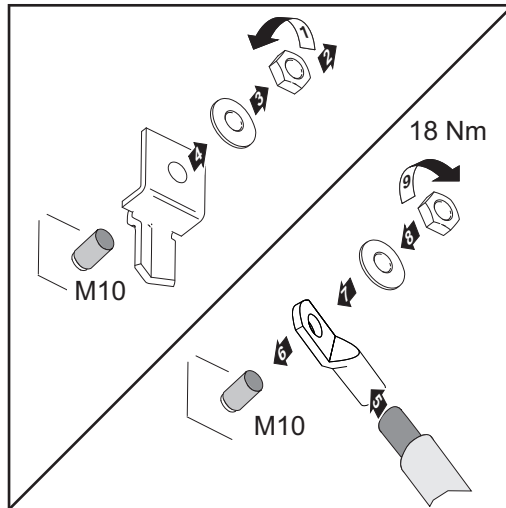

4x

L1
L2
L3
N

+

PE

Maximum fuse rating on alternating current side

Inverter	Phases	Nominal output	Fuse protection
Fronius Agilo 75.0-3	3	100 kVA	3 x 200 A
Fronius Agilo 100.0-3	3	100 kVA	3 x 200 A

Connecting an external AC supply for the inverter

Procedure for connecting an external AC supply for the inverter (e.g. to provide an external supply to controllers or fans):

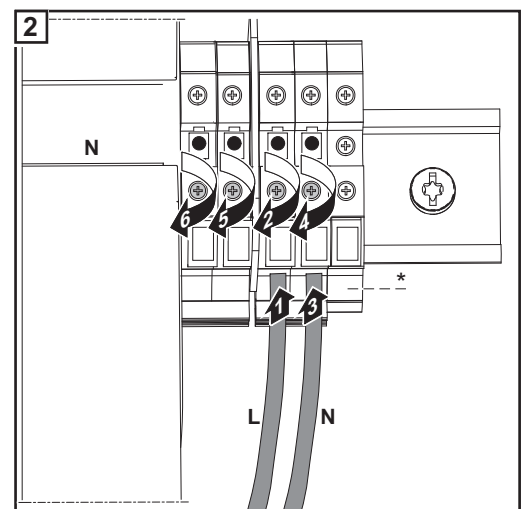
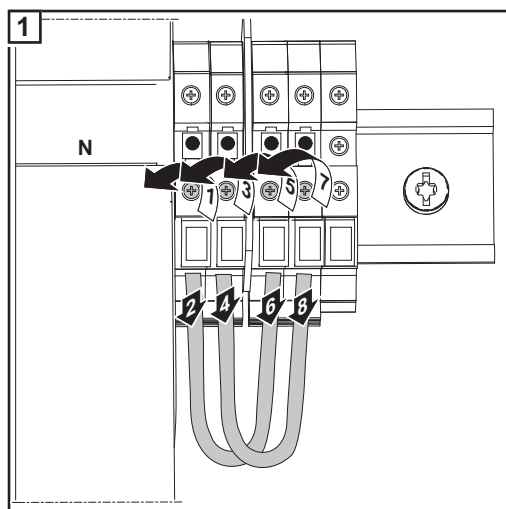

* If present, connect ground conductor to grounding terminal 9

Fitting and connecting optional overvoltage protection

General

Standard type II overvoltage protection can be fitted in the inverter as an option:

- for the DC side,
- for the AC side,
- for the external AC supply of the inverter.

DIN rails and passage openings to the AC and DC terminals for the cables are provided in the inverter for fitting overvoltage protection.

The existing remote contacts on the overvoltage protection can be connected to the NO/ alarm contact terminals in the data communication area. In the event of a fault, the incoming signals can then be evaluated and shown on the display.

Overvoltage protection is not included in the scope of supply of the inverter. The engineer is responsible for the correct selection of the relevant overvoltage protection so as to comply with national and international regulations.

Safety



WARNING! Work that is carried out incorrectly can cause serious injury and damage. Overvoltage protection must only ever be installed and connected by a qualified electrical installation engineer!

Follow the safety rules!

Make sure that both the AC side and the DC side of the inverter are de-energised before carrying out any installation or connection work.



NOTE! Installing a Type I overvoltage protection device in the inverter is prohibited.

Fitting and connecting overvoltage protection on the DC side

IMPORTANT!

- Provide a separate grounding terminal for each overvoltage protection device
- Make sure that the cables have adequate insulation resistance.

- 1 Fit overvoltage protection to the DIN rail on the DC side according to the manufacturer's instructions
- 2 Fit a grounding terminal to the DIN rail on the DC side
- 3 Remove the 2 blank screw joints on the DC side
- 4 Insert 2 M20 screw joints from the inverter's accessories kit into the openings and secure them with the hexagonal nuts of the blank screw joint
- 5 Prepare the cable:
 - Strip the cable on the overvoltage protection side
 - Fit the M10 cable lug on the DC connection side

Max. cable cross-section must comply with the instructions of the overvoltage protection manufacturer.

- 6 Open the M20 screw joints
- 7 Feed the cable through
- 8 Connect the cable to the overvoltage protection device according to the manufacturer's instructions

- 9 Use the M10 hexagonal nut and the washer to connect the cable with the correct polarity at the central M10 threaded bolt of the relevant DC connection
- 10 Close the M20 screw joints
- 11 Connect the overvoltage protection to the grounding terminal
- 12 If available, connect the remote contacts of the overvoltage protection device with two cables to the NO/alarm contact terminals in the data communication area

Fitting and connecting overvoltage protection on the AC side

IMPORTANT!

- Provide a separate grounding terminal for each overvoltage protection device
- Make sure that the cables have adequate insulation resistance.

- 1 Fit overvoltage protection to the DIN rail on the AC side according to the manufacturer's instructions
- 2 Fit a grounding terminal to the DIN rail on the AC side
- 3 Remove 3-4 blank screw joints on the AC side, depending on the overvoltage protection
- 4 Insert 3-4 M20 screw joints from the inverter's accessories kit into the openings and secure them with the hexagonal nuts of the blank screw joint
- 5 Prepare the cable:
 - Strip the cable on the overvoltage protection side
 - Fit the M10 cable lug on the AC connection side

Max. cable cross-section must comply with the instructions of the overvoltage protection manufacturer.

- 6 Open the M20 screw joints
- 7 Feed the cable through
- 8 Connect the cable to the overvoltage protection device according to the manufacturer's instructions
- 9 Connect the cable to the upper part of the relevant AC connection in the correct phase sequence
Tightening torque = 18 Nm
- 10 Close the M20 screw joints
- 11 Connect the overvoltage protection to the grounding terminal
- 12 If available, connect the remote contacts of the overvoltage protection device with two cables to the NO/alarm contact terminals in the data communication area

Fitting and connecting overvoltage protection for the AC- supply

IMPORTANT!

- Provide a separate grounding terminal for each overvoltage protection device
- Make sure that the cables have adequate insulation resistance.

- 1 Fit overvoltage protection to the DIN rail on the AC side according to the manufacturer's instructions
- 2 Fit a grounding terminal to the DIN rail
- 3 Strip the cable on both sides

Max. cable cross-section must comply with the instructions of the overvoltage protection manufacturer.

- 4 Connect cables L1 and N on the overvoltage protection device according to the manufacturer's instructions

- 5 Run the cable to the 2-pin automatic circuit breaker to safeguard the AC power supply
- 6 Connect cables L1 and N on the automatic circuit breaker in the correct phase sequence
- 7 Connect the overvoltage protection to the grounding terminal
- 8 If available, connect the remote contacts of the overvoltage protection device with two cables to the NO/alarm contact terminals in the data communication area
- 9 Bind the cable with cable ties if necessary

Connecting the DC cable to the inverter

General comments regarding solar modules

To enable suitable solar modules to be chosen and to use the inverter as efficiently as possible, it is important to bear the following points in mind:

- If insolation is constant and the temperature is falling, the open circuit voltage of the solar modules will increase. The open circuit voltage must not exceed 950 V. If the open circuit voltage exceeds 950 V, the inverter will be destroyed and no warranty claims will be entertained.
- More exact values for dimensioning the solar modules can be provided by suitable calculation programs, like the Fronius Solar.configurator (which can be downloaded from www.fronius.com).



NOTE! Before connecting the solar modules, check:

- that the voltage specified by the manufacturer corresponds to the actual measured voltage.
- whether the solar modules need to be grounded.

DC connections

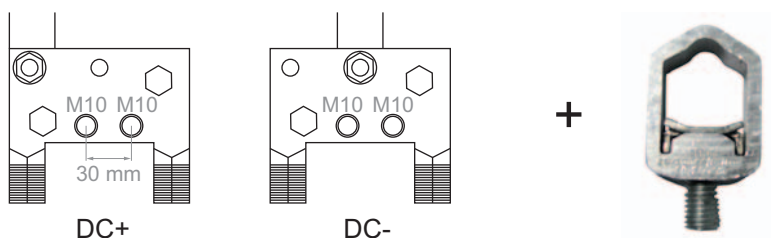

IMPORTANT! Only the following cables may be connected to V-type terminals:

- RE (round single-wire)
- RM (round multi-strand)
- SE (sector-shaped single-wire)
- SM (sector-shaped multi-strand)
- fine-core cables, in conjunction with ferrules only

Fine-core cables without ferrules may only be connected to the M10 threaded bolts of the DC connections using a suitable M10 cable lug; tightening torque = 30 Nm

Connecting aluminium cables

Aluminium cables can also be connected to the DC connections.



NOTE! When connecting aluminium cables:

- observe national and international guidelines regarding the connection of aluminium cables
- follow the instructions of the cable manufacturer
- Once a year, make sure that the cables are securely connected according to the specified torque.

Max. cross-section of DC cables

The DC connections on the inverter are designed for cables with a cross-section of max. 240 mm².

With this maximum cross-section, 2 cables can be connected to each pole.

Safety



WARNING! An electric shock can be fatal. Danger due to grid voltage and DC voltage from solar modules.

- Make sure that both the AC side and the DC side of the inverter are de-energised before making any connections.
- Only an authorised electrical engineer is permitted to connect this equipment to the public grid.



CAUTION! Risk of damage to the inverter as the result of incorrectly tightened terminals. Incorrectly tightened terminals can cause heat damage to the inverter that may result in a fire. When connecting AC and DC cables, ensure that all the terminals are tightened to the specified torque.

Connecting DC cables

- 1 Remove contact protectors
- 2 Feed the DC cable into the inverter, observing the bending radii specified by the cable manufacturer
- 3 Strip at least 25 mm of insulation from the DC cable
- 4 Align the DC cable with the DC connections

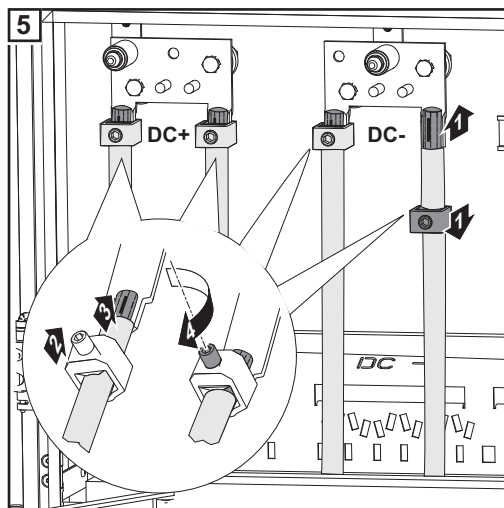

- Push the DC terminal over the DC cable
- Push the DC terminal up and over the DC connection and the bare end of the cable
- Tighten the DC terminal:
6 mm Allen key
- Tightening torque = 25 Nm
- Repeat this process for every DC cable

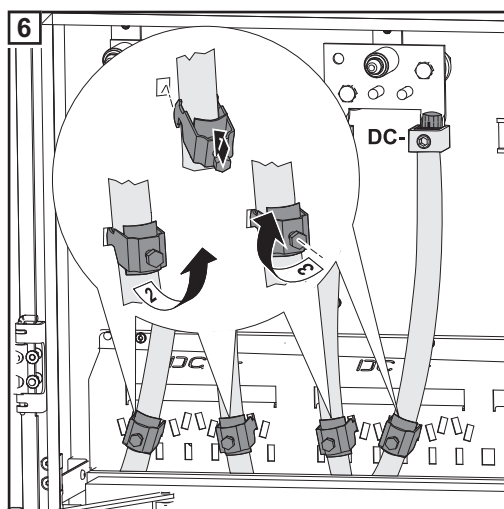

- Place the DC cable in the clamp of the strain-relief device
- Attach the clamp of the strain-relief device to the rail
- Secure the DC cable with the clamp of the strain-relief device
- Repeat this process for every DC cable

- 7 Fit the contact protectors



NOTE! Different openings are available on the rail for attaching the clamps of the strain-relief device, depending on the cable routing.

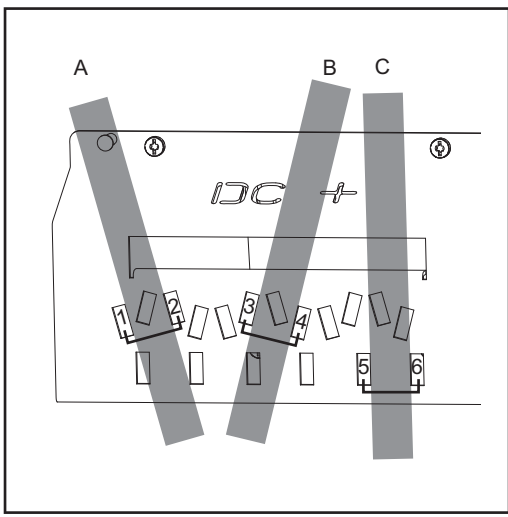

e.g.:

- A cable routed at an angle from the bottom right - attach the clamp for the strain-relief device to positions 1 and 2
- B cable routed at an angle from the bottom left - attach the clamp for the strain-relief device to positions 3 and 4
- C vertical cable routing - attach the clamp for the strain-relief device to positions 5 and 6

Connecting DC cables with a cable lug

Alternatively, a DC cable with a cable lug can be connected to the M10 threaded bolts on the DC connections in order to connect the DC cables to the V-type terminals.

NOTE! Ensure the polarity is correct when connecting the DC cables.

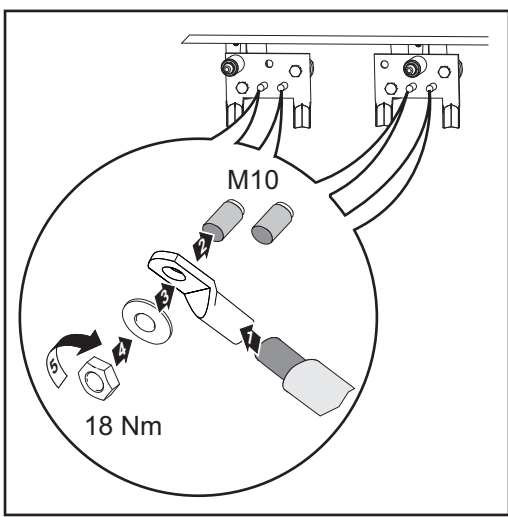

Fuse protection against polarity reversal of DC cables

The inverter is fitted with a fuse to protect against any polarity reversal of the DC cables. The fuse will blow if the inverter is activated with the polarity of the DC cables reversed. Status code 307 "DC low" is shown on the display, even in the event of sufficient levels of insulation.

Should this occur, the reverse polarity protection fuse must be replaced as described under "Replacing fuses" in the "Troubleshooting and maintenance" section.

Grounding the solar modules in the inverter

General

Some manufacturers of solar modules stipulate that the module must be grounded.

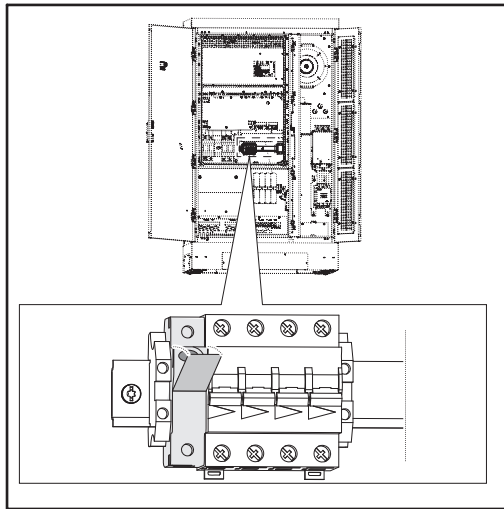

Inside the inverter is a means for grounding solar modules to the negative pole via a fuse.

Locking ring for solar module grounding on the negative pole

Grounding the solar module to the negative pole via a fuse

Grounding the solar module to the negative pole via a fuse

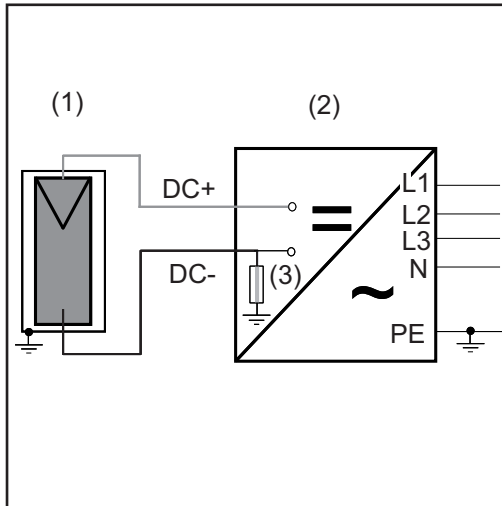

- (1) Solar module
- (2) Inverter
- (3) Fuse

Fronius recommends the following fuse when grounding the solar module to the negative pole:

nominal current rating 3 A / 1000 V, fuse dimensions 10 x 38 mm

IMPORTANT! Fuses for grounding the solar module are not part of the scope of supply of the inverter. If the manufacturer of the solar module stipulates that grounding is required, an appropriate fuse must be ordered separately



WARNING! An electric shock can be fatal. Danger of electric shock if the solar module is not grounded or is not grounded properly.
To comply with IEC 62109-2, any grounding required by the manufacturer of the solar module within the inverter must only be carried out via the specified fuse.

Safety

WARNING! An electric shock can be fatal. Danger from DC voltage in solar modules. The inverter's insulation monitoring is deactivated when the solar modules are grounded.

- Ensure that grounded solar modules are designed so that they are isolated according to Protection Class II
- Place the relevant safety sticker in a clearly visible place on the photovoltaic system
- Configure the inverter so that a warning message is displayed if the fuse trips.



Warning sticker for solar module grounding

IMPORTANT! The warning sticker and the fuse for grounding the solar module are not part of the scope of supply of the inverter and must be ordered separately.

Configuring the inverter for grounded solar modules

The inverter's insulation monitoring must be deactivated when the solar modules are grounded. At the second level of the Setup menu, the inverter must be configured so that when the grounding fuse trips, an error message is displayed or the inverter is switched off (according to the country setup). Access code 22742 must be entered in order to access the 2nd level of the Setup menu.

Grounding the solar module on the negative pole: inserting a fuse



WARNING! An electric shock can be fatal. Danger from DC voltage in solar modules.
The DC main switch is only to be used to de-energise the power stage set. Grounding of the solar module on the negative pole remains in effect, even when the DC main switch is switched off. Do not under any circumstances touch DC+ or DC-.

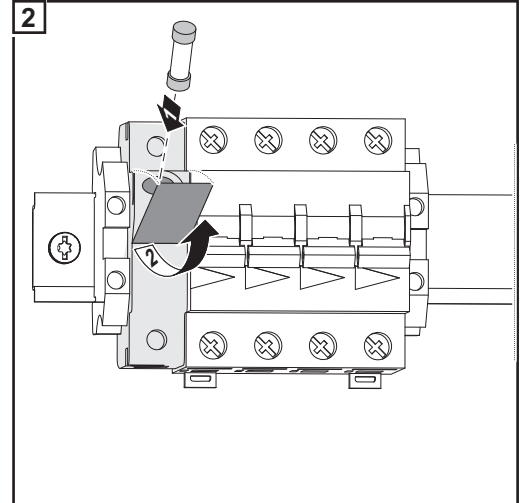
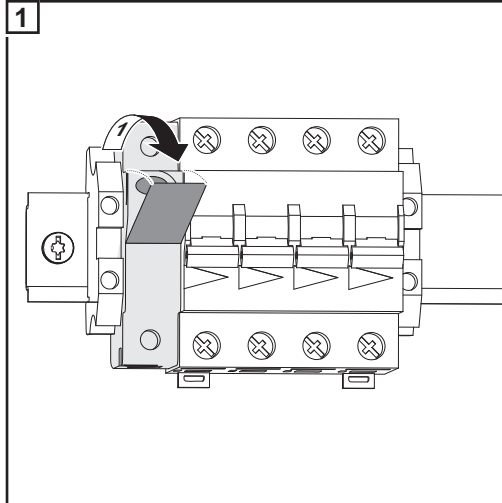

Inserting the fuse grounds the solar modules on the negative pole.

Closing the inverter

Closing the inverter

CAUTION! An inadequate ground conductor connection can cause serious injury or damage. The screws on the air inlet grille and on the covers provide a suitable ground conductor connection for the housing; these screws must not under any circumstances be replaced by other screws that do not provide a reliable ground conductor connection.

- 1 Check that all covers and contact protection devices are fitted; fit any covers and contact protection devices that are missing

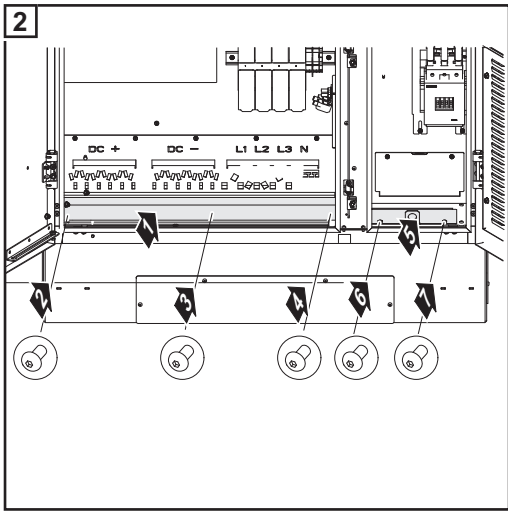

Tightening torque = 3 Nm

NOTE! To avoid damaging the DC main switch, only close the door of the inverter once the switch itself is switched to the "OFF" position.

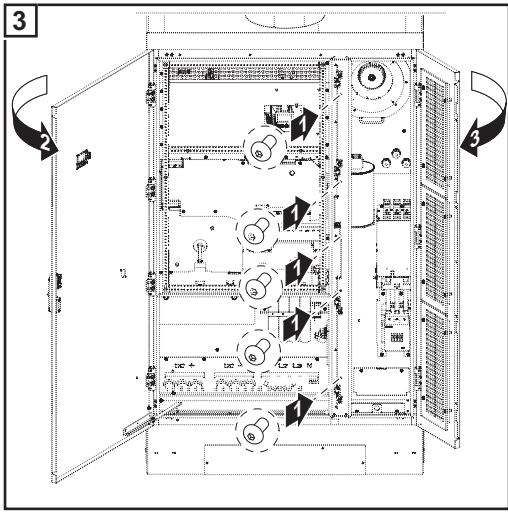

Tightening torque = 3 Nm

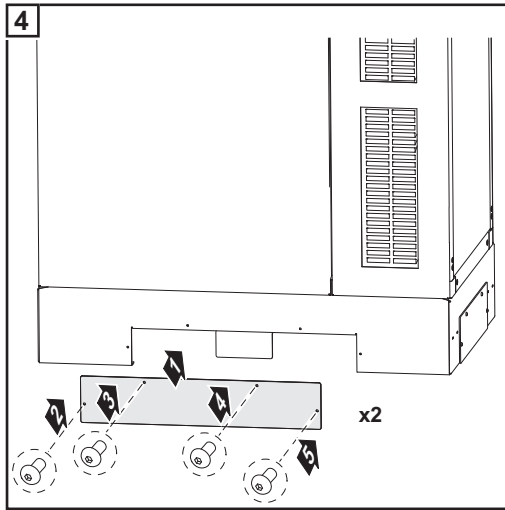

Tightening torque = 3 Nm

Using for the first time

Factory configuration

The inverter is preconfigured in the factory. The language and the time must be set when the inverter is used for the first time.

Refer to the section in this manual entitled 'The Setup Menu' for the individual configuration options.

Using for the first time

After connecting the DC cable to the inverter and the inverter to the grid (AC):

- 1 Insert covers and contact protection
- 2 Close and secure air inlet grilles
- 3 Close door
- 4 Turn the DC main switch to the - 1 - position

If the solar modules are producing enough voltage, the inverter will enter the startup phase. The inverter is about to start up automatically.

Once the inverter has completed its automatic startup, the operating state LED will show steady green.

Provided that energy continues to be fed into the grid, the operating state LED will remain steady green to confirm that the inverter is functioning correctly.

A window then appears for setting the language:



- 5 Use the 'Up' and 'Down' keys to select the desired language
- 6 Press the 'Enter' key to set the language

The time and the date must then be set:



The time is displayed (HH:MM:SS, 24-hour format), the hours field starts flashing.

- 7 Use the 'Up' and 'Down' keys to select a value for the hour
- 8 Press the 'Enter' key



The minutes field starts flashing.

- 9 Repeats steps 7 and 8 for the minutes and seconds until...



the set time starts flashing.

- ↵ **10** Press the 'Enter' key



The time is applied and the date now appears (DD.MM.YYYY), the day field starts flashing.

- + - **11** Use the 'Up' and 'Down' keys to select a value for the day
- ↵ **12** Press the 'Enter' key



The month field starts flashing.

- 13** Repeat steps 11 and 12 for the month and the last 2 digits of the year until ...



the set date starts flashing.

- ↵ **14** Press the 'Enter' key

If setting of the language and the time are skipped by pressing the Back key and no settings are made during the setup, these two prompts appear again the next time the inverter is started.

Configuring the inverter for existing solar module grounding



NOTE! If the solar module is already grounded on the negative pole, the appropriate grounding method must be set in the 'Basic Service Menu' when the inverter is switched on.

The access code 22742 must be entered in order to access the 'Basic Service Menu'.

- 1** Confirm any status codes that are displayed by pressing 'Enter'
- 2** Press the 'Menu' key
- 3** Press the unassigned 'Menu / Esc' key 5 times



- 4** Enter the access code 22742

The inverter is now in the 'Basic Service Menu' and the first parameter 'DC operating mode' is displayed.



- + - **5** Use the 'Up' and 'Down' keys to select the 'Grounding Mode' parameter
- ↵ **6** Press the 'Enter' key



'Grounding method' is displayed.

- ↵ **7** Press the 'Enter' key

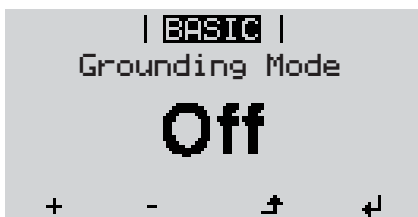

The currently selected grounding method is displayed.

Off = un-grounded system (no solar module grounding)
Factory setting

- + - **8** Use the 'up' or 'down' buttons to select the 'Negative' grounding method

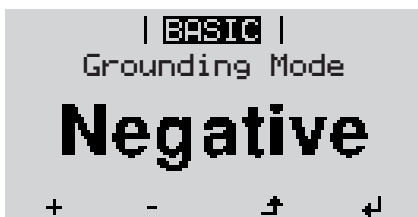

Negative = solar module grounded on the negative pole:

- ↵ **9** Press the 'Enter' key



The 'Negative' grounding method is applied, 'Grounding method' and 'Grounding monitoring' are displayed.

- ⏮ **10** To quit the 'Basic Service Menu', press the 'Esc' key twice

Operation

Controls and indicators

Controls and indicators

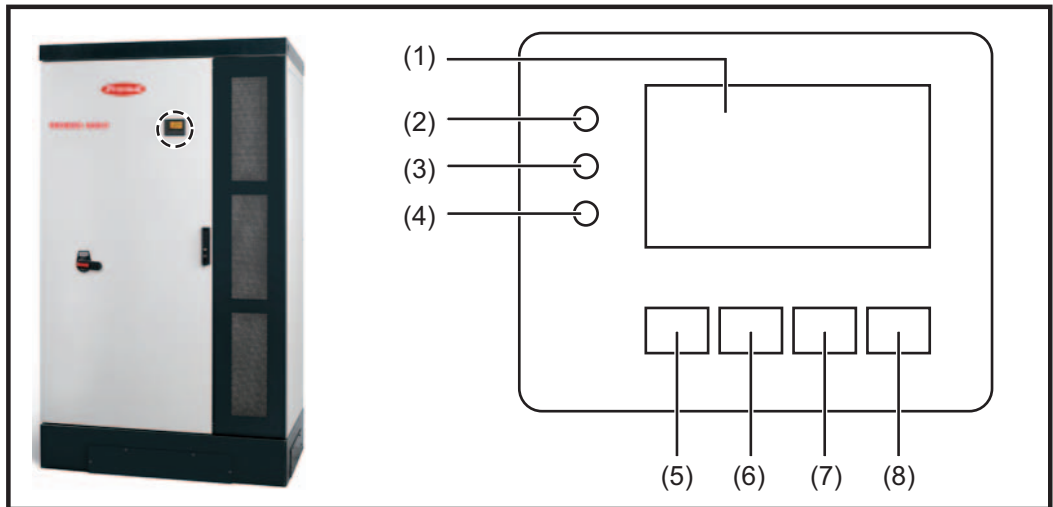

Item	Description
(1)	Display for displaying values, settings and menus
	Monitoring and status LEDs
(2)	General status LED (red) lights when there is a status code on the display
(3)	Startup LED (orange) for displaying whether the inverter is in its startup phase or is on standby
(4)	Operating state LED (green) for displaying the operating state
	Function keys - allocated different functions depending on the selection:
(5)	'Left/up' key for navigating to the left and up
(6)	'Down/right' key for navigating down and to the right
(7)	'Menu/Esc' key for switching to the menu level for quitting the Setup menu
(8)	'Enter' key for confirming a selection

Display

Power for the display comes from the mains voltage. The display is therefore available permanently.

IMPORTANT! The display on the inverter is not a calibrated measuring device. A slight inaccuracy of a few percent from the energy meter used by the energy supply company is intrinsic to the system. A calibrated meter will be needed to calculate the bills for the energy supply company.

NOW	Display modes
AC Output Power	Parameter explanation
9400 kW	Display of values and units as well as status codes
← ↓ ↵ ↻	Function key assignment

Display areas in display mode

(*) SETUP 1 ④	Inverter no. Storage sym. (**)
↑ Standby	Display modes
↑ Contrast	Preceding menu items
↓ Backlight	Currently selected menu item
↓ Language	Next menu items
↓ Currency	
← ↓ ↵ ↻	Function key assignment

Display areas in setup mode

- (*) Scroll bar
- (**) INV no. = Inverter DATCOM number, Save symbol - appears briefly while the selected values are being saved

Symbols showing function key allocation

The following symbols are displayed to indicate the function key assignments:

←	Navigate: left	
↑	Navigate: up	■ □ □ □
+	Increase value	
→	Navigate: right	
↓	Navigate: down	□ ■ □ □
-	Reduce value	
↵	Menu / Back	□ □ ■ □
↻	Enter	□ □ □ ■

Monitoring and status LEDs

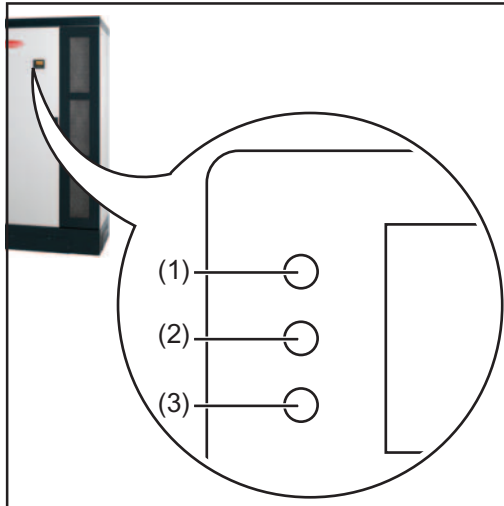

- (1) General status LED (red)
- (2) Startup LED (orange)
- (3) Operating state LED (green)

LED	Colour	Activity	Explanation
(1)	red	lights up	<p>General status: the relevant status code is shown on the display</p> <p>Interruption while feeding energy into the grid</p> <p>While error handling (the inverter waits for an acknowledgement or for an error to be rectified)</p>
(2)	orange	lights up	<p>The inverter will enter its automatic startup or self-test phase as soon after sunrise as the solar modules are delivering sufficient power</p> <p>The inverter has been switched to standby mode in the setup menu = grid power feed operation switched off manually</p> <p>The inverter software is being updated</p>
(3)	green	lights up	<p>The LED lights up after the automatic startup phase of the inverter, provided energy is being fed into the grid.</p> <p>The photovoltaic system is working properly.</p>

A list of the relevant status codes, and causes and remedies can be found in the 'Status diagnosis and repair' section under 'Maintenance and service'.

Startup phase and feeding energy into the grid

Startup phase

Once it has been switched on automatically, the inverter carries out the following tests and checks:

- a) Self-test of all important inverter components - the inverter runs through a virtual checklist
- b) Synchronisation with the grid
- c) Startup test
Before the inverter starts feeding energy into the grid, the grid conditions according to national regulations are tested.
Depending on the country-specific regulations, the startup test can last just a few seconds or take several minutes.

During the startup phase:

- the operating state LED shows orange,
- the string 'warte...' (wait...) and the currently tested component are displayed, e.g.:



Feeding energy into the grid

- Once the tests have been completed the inverter starts feeding energy into the grid
- The display shows the current energy level that is being fed into the grid, e.g.:

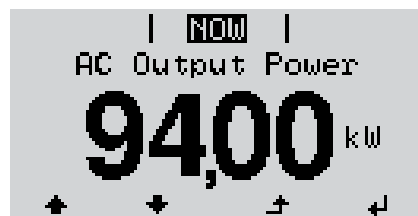

- The operating state LED shows green, the inverter is working.

Navigation at the menu level

Activate display backlighting

1 Press any key

The display backlighting is activated.

The option remains in the setup menu to set the display backlighting so that it is on all the time or off all the time.

Automatic deactivation of display backlighting / change to display mode 'NOW'

If no key is pressed for 2 minutes,

- the display backlighting switches off automatically and the inverter switches to display mode 'NOW' (assuming the display backlighting is set to automatic).
- The switchover to the 'NOW' display mode can happen from anywhere within the display modes or the Setup menu, with the exception of the 'Standby' menu item.
- The amount of energy currently fed in is displayed.

Open menu level

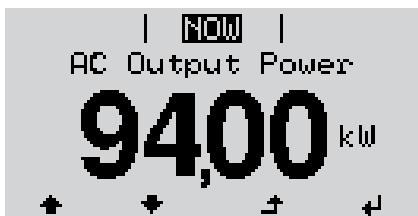

1 Press the 'Menu' key



'Menu' will appear on the display

The inverter is now at the menu level.

From the menu level

- the required display mode can be selected
- the Setup menu can be accessed

The display modes

The display modes

The following display modes are available on the inverter:

Display mode 'NOW'	Displays real-time values
Display mode 'TODAY'	Displays values for energy fed into the grid today
Display mode 'YEAR'	Displays values for energy fed into the grid during the current calendar year
Display mode 'TOTAL'	Displays values for energy fed into the grid since the inverter was originally commissioned.

Choosing a display mode



- 1 Open menu level
- 2 Use the 'left' and 'right' keys to select the required display mode



- 3 Press the 'Enter' key



The first value of the selected display mode is displayed.

Overview of display values

Display mode	Unit	Display value	
'NOW'	W	Energy supplied Day characteristic	
	V	Three-phase AC grid voltage	
	A	Three-phase AC output current	
	Hz	AC grid frequency	
	V	PV array voltage	
	A	PV array current	
	°C	Ambient temperature	
	rpm	Fan speed	
	HH:MM _{SS}	Time	
	DD.MM _{YY}	Date	
	'TODAY' 'YEAR'	kWh / MWh	Energy Supplied Day characteristic ('TODAY')
		Currency	Yield
'TOTAL'	g / kg	CO ₂ saving	
	W	Max. output power	
	V	Max. three-phase AC grid voltage	
	V	Max. PV array voltage	
	HH:MM	Operating hours	

Values in display mode 'NOW'

Choosing a display mode

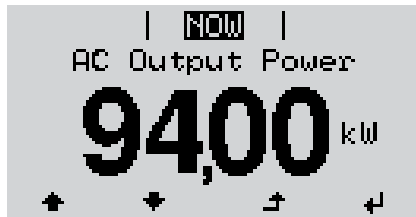

First value in display mode 'NOW'

- ↔ **1** Choose display mode 'NOW'
The first value in display mode 'NOW' appears
- ↓ **2** Scroll to the next display value using the 'Down' key
- ↑ Scroll back up using the 'Up' key

Values in display mode 'NOW'

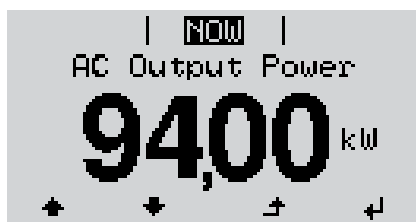

AC Output Power

Power (in watts) currently being fed into the grid

Press the 'Enter' key to display the day characteristic.

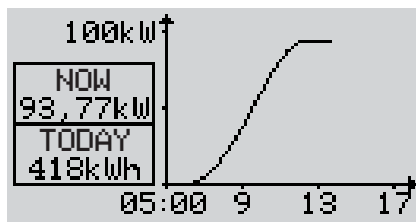

Day characteristic

Displays a plot showing the power output during the day. The time axis is scaled automatically.

Press the 'Back' key to remove the display

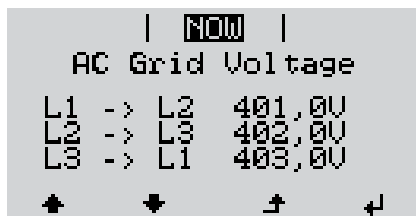

AC Grid Voltage

Phase voltage (Volt)

Press the 'Enter' key to display the string voltage.

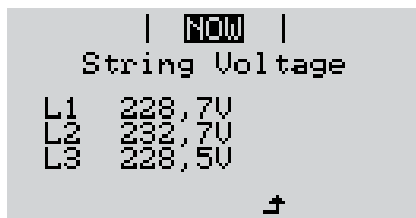

String Voltage

displays the string voltage of each phase.

Press the 'Back' key to remove the display

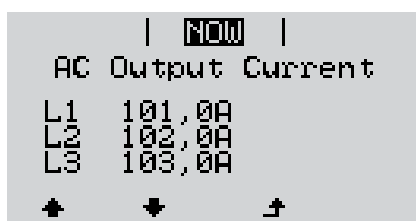

AC Output Current

Phase current currently being fed into grid (Ampere)

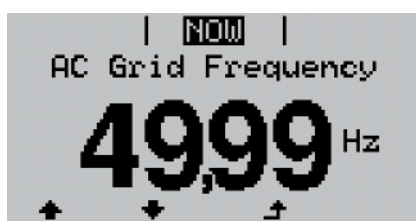

AC Grid Frequency
(Hertz)

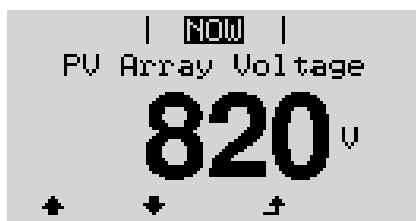

PV Array Voltage
Voltage currently present on the solar modules
(Volt)



PV Array Current
Current that is being supplied at present by the solar modules (Ampere)

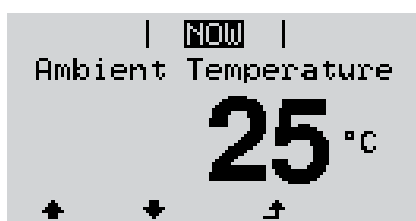

Ambient Temperature
Temperature of the air sucked in to cool the inverter
(°C)



Fan Speed
(rpm)



Time
If the time is changed on an inverter or a system add-on, it will also be changed in any other devices that are connected via Fronius Solar Net.



Date
If the date is changed on an inverter or a system add-on, it will also be changed in any other devices that are connected via Fronius Solar Net.

Values in display modes 'TODAY / YEAR / TOTAL'

Choose display mode 'TODAY / YEAR / TOTAL'



First value in display mode 'TODAY'

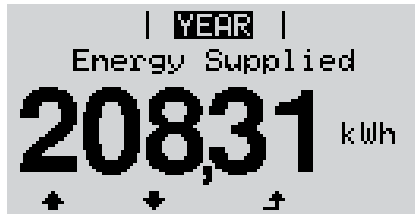

First value in display mode 'YEAR'



First value in display mode 'TOTAL'

↔ **1** Choose display mode 'TODAY' or display mode 'YEAR' or display mode 'TOTAL'

The first value in the selected display mode appears.

↓ **2** Scroll to the next display value using the 'Down' key

↑ Scroll back up using the 'Up' key

Values in display modes 'TODAY / YEAR / TOTAL'



Energy Supplied

Energy fed into the grid during the period in question (kWh / MWh)

Press the 'Enter' key to display the day characteristic (only in display mode 'TODAY')

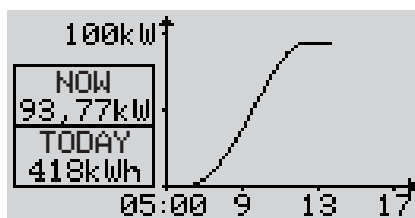

Day characteristic

Displays a plot showing the power output during the day. The time axis is scaled automatically.

Press the 'Back' key to remove the display

There may be discrepancies with values displayed on other measuring instruments because of differences in measuring methods. As far as adding up the energy fed in is concerned, the only binding display values are those produced by the calibrated measuring device provided by the electricity supply company.



Yield

Amount of money earned during the period in question (currency can be selected in the Setup menu)

Like the energy supplied figure, the yield figure may also exhibit discrepancies with other measured values.

The 'Setup Menu' section explains how to select a currency and charge rate. The factory setting depends on the respective country setup.



CO₂ Savings

Amount by which CO₂ emissions were reduced during the period in question (g / kg)

The value for CO₂ savings depends on the power station facilities and corresponds to the CO₂ emissions that would be released when generating the same amount of energy. The factory setting is 0.59 kg / kWh (source: DGS – Deutsche Gesellschaft für Sonnenenergie e.V. (German Society for Solar Energy))

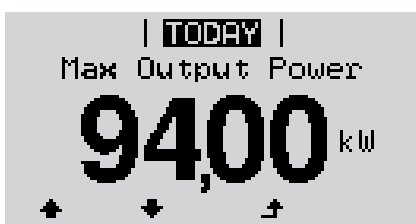

Max. Output Power

Largest amount of power (W) fed into the grid during the period in question

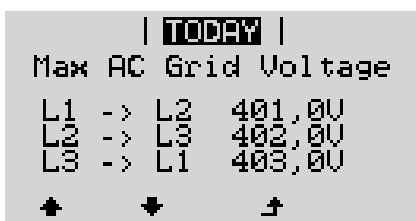

Max. AC Grid Voltage

Highest AC grid voltage (V) measured during the period in question

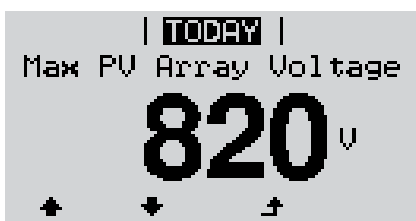

Max. PV Array Voltage

Highest PV array voltage (V) measured during the period in question



Operating Hours

Length of time the inverter has been working (HH:MM).

Although the inverter does not operate during the night, the data required for the Sensor Box option is logged and stored 24 hours a day.

IMPORTANT! A prerequisite for the correct display of day and year values is that the time is set correctly.

The Setup menu

Initial setting

After completing commissioning the inverter is pre-configured depending on the country set-up.

The SETUP menu item allows the initial settings of the inverter to be changed easily to bring it in line, as closely as possible, with the preferences and requirements of the user.

Accessing the setup menu



'SETUP' menu level selected

- ↗ **1** Switch to the menu level (press the 'Menu' key)
- ↔ **2** Select 'Setup' mode using the 'Left' or 'Right' keys
- ↵ **3** Press the 'Enter' key



'Standby' menu item

The first menu item in the Setup menu, 'Standby', is shown.

Move up and down the menu items



Example: 'Standby' menu item

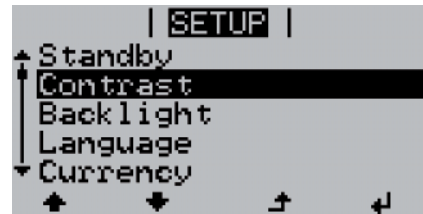

Example: 'Contrast' menu item

- 1** Accessing the setup menu
- ↕ **2** Use 'Up' and 'Down' keys to move between the available menu items

Menu items in the Set-up menu

Standby

Manual activation / deactivation of Standby mode

- The power electronics are switched off in standby mode. No energy is fed into the grid.
- The Startup LED will show steady orange.
- In Standby mode, no other menu item in the Setup menu can be accessed or adjusted.
- The automatic switchover into the 'NOW' display mode after 2 minutes of keyboard inactivity does not occur.
- Standby mode can only be terminated manually by pressing the 'Enter' key.
- Feeding energy into the grid can be resumed at any time (deactivate 'Standby').

Switching off Standby mode (manually switching off feeding energy into the grid):

- 1 Select the 'Standby' menu item
- 2 Press the 'Enter' key

'STANDBY' and 'ENTER' appear alternately on the display.
Standby mode is now active.
The Startup LED shows steady orange.

Resuming feeding energy into the grid:

'STANDBY' and 'ENTER' appear alternately on the display when in Standby mode.

- 1 Press the 'Enter' key to resume feeding energy into the grid

The 'Standby' menu item is displayed.
At the same time, the inverter enters the startup phase.
The operating state LED shows steady green when feeding energy into the grid has been resumed.

Contrast

Adjusts contrast on the display.

Unit	-
Setting range	0 - 10
Factory setting	5

Since the contrast is temperature-dependent, when the ambient conditions change it may be necessary to adjust the 'Contrast' menu item.

Backlighting	Initial setting for display backlighting	
	Unit	-
	Setting range	AUTO / ON / OFF
	Factory setting	AUTO
	AUTO:	Display backlighting is activated by pressing any key. If no key is pressed for 2 minutes, the display backlighting will go off again.
	ON:	The display backlighting remains permanently on when the inverter is switched on.
	OFF:	The display backlighting is permanently switched off.
	IMPORTANT! The 'Backlight' menu item only relates to the backlighting of the display and the keys.	

Language	Setting the display language	
	Unit	-
	Display area	German, English, French, Dutch, Italian, Spanish, Czech, Slovak
	Factory setting	(depends on country setup)

Currency	Sets the currency and charge rate for the energy fed into the grid	
	Unit	-
	Display area	Currency/ feed-in tariff
	Factory setting	(depends on country setup)

CO₂ factor	Setting the CO ₂ reduction factor	
	Unit	kg/kWh
	Setting range	00.01 - 99.99
	Factory setting	0.59 kg/kWh

Yield

Setting

- of an OFFSET value for the total energy display
- of a measuring offset factor for the day, year and total energy display

Setting range Meter deviation / meter unit of measurement / meter calibration

Meter deviation

Input of a value for the fed-in energy that will be added to the energy currently fed in (e.g. carry-over value when replacing an inverter)

Unit	Wh
Setting range	Five digits
Factory setting	0

Meter unit of measurement

Input of a unit (k..., M...)

Unit	-
Setting range	k / M
Factory setting	-

Meter calibration

Input of a correction value to ensure that the value shown on the inverter display corresponds with the calibrated display on the electricity meter

Unit	%
Setting range	-5.0 - +5.0
Factory setting	0

DATCOM

Checking data communications, entering the inverter number, protocol settings

Setting range Status / inverter number / protocol type

Status

Indicates data communication is taking place via a Fronius Solar Net or that a data communications error has occurred

Inverter number

Sets the number (= address) of the inverter in a system with several solar inverters

Unit	-
Setting range	00 - 99 (00 = 100th inverter)
Factory setting	01

IMPORTANT! If a number of inverters are linked together in a data communications system, assign a unique address to each one.

Protocol type

Specifies the communications protocol to be used to transfer the data:

Unit	-
Setting range	Solar Net / Interface
Factory setting	Solar Net

Device Info

For displaying the settings that will be of relevance to an energy supply company. The values shown will depend on the country setup or the device-specific settings of the inverter.

Display area	General / MPP Tracker / Grid Monitoring / Voltage Limits / Frequency Limits / P AC Reduction
--------------	--

General:

Setup	Country setup
Version	Version of country setup
Group	Group for updating the inverter software

MPP Tracker:

DC Mode	DC mode
FIX	Voltage value in V for fixed voltage operation
User	Voltage value in V for MPP User operation

Grid Monitoring:

GMTi	Start-up time of inverter in s
GMTr	Reconnection time in s following a grid fault
ULL	Mean grid voltage over 10 minutes in V.
LL Trip	Trip time for long-term voltage monitoring

Voltage Limits:

UIL max	Upper inner grid voltage in V
UIL min	Lower inner grid voltage in V
UOL max	Upper outer grid voltage limit value in V
UOL min	Lower outer grid voltage limit value in V

Frequency Limits:	
FIL max	Upper inner grid frequency in Hz
FIL min	Lower inner grid frequency in Hz
FOL max	Upper outer grid frequency limit value in Hz
FOL min	Lower outer grid frequency limit value in Hz

LVFRT:	
Status	Status of the LVFRT function (Low Voltage Fault Ride Through, according to BDEW TR3 5.7)
DB min	Dead Band Value min. Lower voltage limit as % for the reactive power feed
DB max	Dead Band Value max. Upper voltage limit as % for the reactive power feed
k-Fac	Gradient showing how much reactive current is fed in as a function of voltage

P AC Reduction:	
Max. P AC	Manual power reduction
GPIS	Softstart function
GFDPRv	Grid frequency-dependent power reduction in %/Hz
GFDPRr	Return to nominal output in %/s (following a grid frequency-induced power reduction)

Device Status For displaying the measured insulation resistance

Display area	Messwertanzeige PV Iso. (Value in MOhm)
--------------	--

Time Setting time and date

Unit	HH:MM, DDMMYYYY
Setting range	Time/date
Factory setting	-

IMPORTANT! The correct time and date is a prerequisite for the correct display of day and year values and the day characteristic.

Status LT The status display of the most recent inverter fault can be displayed.

IMPORTANT! Due to the low level of insolation early in the morning and in the evening, the status codes 306 (Power low) and 307 (DC low) are displayed routinely at these times of day. These status messages do not indicate any kind of fault.

- Press the 'Enter' key to see the status of the power stage set and the most recent fault
- Use the 'Up' and 'Down' keys to scroll through the list
- Press the 'Back' key to close the status and fault list

Grid Status The five most recent grid faults can be displayed:

- Press the 'Enter' key to see the five most recent grid faults
- Use the 'Up' and 'Down' keys to scroll through the list
- Press the 'Back' key to close the grid fault display

Fan test To check that the fan is working correctly

Unit	-
Setting range	Start (Progress)
Factory setting	-

The fan test is started by pressing the 'Enter' key.
While the test is ongoing, its 'Progress' is shown on the display.

OK	Fan test successful
Fail	Fan is defective; the associated status code is displayed in 'NOW' view mode.

Version Displays the version and serial numbers of the PC boards in the inverter (e.g. for service purposes)

Unit	-
Display area	Display / Display Software / Interface / SmartMedia Card / Control / Control Software / Monitoring / Monitoring Software / Interface
Factory setting	-

Setting and displaying the menu items

Setting the menu items, general

- 1 Accessing the set-up menu
- 2 Use the 'Up' or 'Down' buttons to select the desired menu item
▲ ▼
- 3 Press 'Enter'
↵

The first digit of a value to be set flashes:

- 4 Use the 'Up' or 'Down' buttons to select a value for the first digit
▲ ▼
- 5 Press 'Enter'
↵

The second digit of the value flashes.

- 6 Repeat steps 4 and 5 until ...

the whole value to be set flashes.

- 7 Press 'Enter'
↵
- 8 Repeat steps 4 - 6 as required for units or other values that are to be set until the appropriate unit or the value flashes.
- 9 Press the 'Enter' key to save and apply the changes.
↵

To discard the changes, press the 'Esc' key.
⬆

The currently selected menu item is displayed.

The available settings are displayed:

- 4 Use the 'Up' or 'Down' buttons to select the desired setting
▲ ▼
- 5 Press the 'Enter' key to save and apply the setting.
↵

To discard the setting, press the 'Esc' key.
⬆

The currently selected menu item is displayed.

Exiting a menu item

- 1 To exit a menu item, press the 'Back' key
↵

The menu level appears:



If no key is pressed for 2 minutes,

- the inverter switches from wherever it is within the Setup menu back to the 'NOW' display mode (exception: 'Standby' menu item),
- the display backlighting goes out,
- The amount of energy currently fed in is displayed.

Practical examples for setting and displaying menu items

The setting and displaying of menu items is illustrated using the following examples:

- Setting the display backlighting
- Setting the currency and feed-in tariff
- Setting the time and date

Setting the display backlighting



- ↑ ↓ 1 Select the 'Backlight' menu item
- ↵ 2 Press the 'Enter' key



The current setting for the display backlighting is shown.

- + - 3 Use the 'Up' and 'Down' keys to select the desired setting for the display backlighting
- ↵ 4 Press the 'Enter' key to apply the setting



The settings for the display backlighting are applied. The 'Backlight' menu item is displayed.

Setting the currency and feed-in tariff

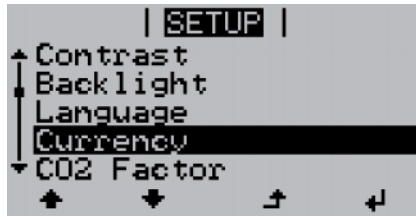

- ↑ ↓ **1** Select the 'Currency' menu item
- ↵ **2** Press the 'Enter' key to apply the currency



The currently selected currency is displayed, factory setting = 'EUR'; the first of the three characters starts flashing.

- + - **3** Use the 'Up' and 'Down' keys to select a value for the first character
- ↵ **4** Press the 'Enter' key



The second character starts flashing.

- 5** Repeat steps 3 and 4 for the second and third characters until...



the selected currency starts flashing.

- ↵ **6** Press the 'Enter' key



The currency is applied and the present feed-in tariff in currency/kWh displayed, factory setting = 0.43 EUR / kWh; the first digit starts flashing.

- + - **7** Use the 'Up' and 'Down' keys to select a value for the first digit (e.g. 0)
- ↵ **8** Press the 'Enter' key



The second digit starts flashing.

- 9** Repeat steps 7 and 8 for the second digit and for each of the three digits after the decimal point until ...



the selected feed-in tariff starts flashing.

- ↵ **10** Press the 'Enter' key

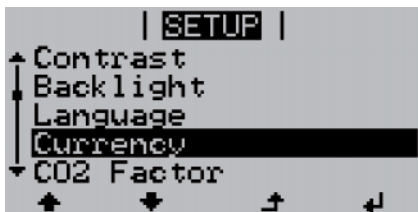

The feed-in tariff is applied and the 'Currency' menu item is displayed.

Setting the time and date



- ↕ **1** Select the 'Time' menu item
- ↵ **2** Press the 'Enter' key

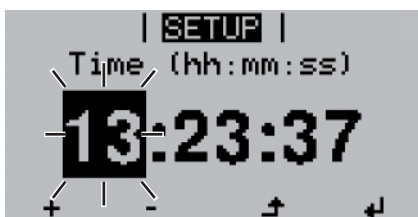

The time is displayed (HH:MM:SS, 24-hour format), the hours field starts flashing.

- + - **3** Use the 'Up' and 'Down' keys to select a value for the hour
- ↵ **4** Press the 'Enter' key

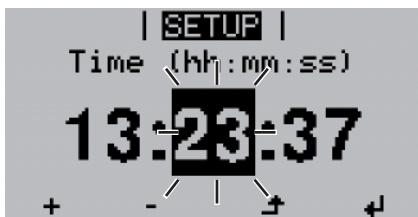

The minutes field starts flashing.

- 5** Repeat steps 3 and 4 for the minutes and seconds until...



the set time starts flashing.

- ↵ **6** Press the 'Enter' key



The time is applied and the date now appears (DD.MM.YYYY), the day field starts flashing.

+ - **7** Use the 'Up' and 'Down' keys to select a value for the day

↵ **8** Press the 'Enter' key

The month field starts flashing.



9 Repeat steps 7 and 8 for the month and the last 2 digits of the year until ...

the set date starts flashing.



↵ **10** Press the 'Enter' key

The date is applied and the 'Time' menu item is displayed.



Switching the key lock on and off

General

The inverter has a key lock function. When the key lock is active, the Setup menu is not accessible, i.e. the setup data cannot be changed accidentally (or maliciously). The code 12321 has to be entered in order to activate / deactivate the key lock.

Switching the key lock on and off



- ↑ **1** Press the 'Menu' key

'MENU' is displayed.

- 2** Press the unassigned 'Menu / Esc' key 5 times



'Access Code' is displayed in the 'CODE' menu; the first digit starts flashing.



- + - **3** Enter the code 12321: use the 'Up' and 'Down' keys to select a value for the first digit of the code.

- ↵ **4** Press the 'Enter' key

The second digit starts flashing.



- 5** Repeat steps 3 and 4 for the second, third, fourth and fifth digit of the access code until ...

the selected code starts flashing.



- ↵ **6** Press the 'Enter' key



'Key Lock' is displayed in the 'LOCK' menu.

- + = **7** Use the 'Up' and 'Down' keys to turn the key lock on or off:

ON = key lock is on (the Setup menu is not accessible)

OFF = key lock is off (the Setup menu is accessible)

- ↵ **8** Press the 'Enter' key

Troubleshooting and maintenance

Status diagnostics and troubleshooting

Displaying status codes The inverter performs a system self diagnosis that automatically detects many faults that may occur and shows them on the display. This means you are promptly made aware of malfunctions in the inverter and the photovoltaic system, or of any installation or operating faults.

If the system self diagnosis has detected a specific fault, the associated status code will be shown on the display.

IMPORTANT! Status codes may sometimes appear briefly as a result of the inverter's control response. If the inverter then continues working with no sign of any problem, this means that there was no fault.

Total failure of the display If the display fails to come on some time after sunrise:
- Check the AC voltage ON the inverter connections:
the AC voltage must be 230 V (+ 10 % / - 5 %)*.

* The mains voltage tolerance depends on the country setup

Class 1 status codes Class 1 status codes generally only arise momentarily and are caused by the public grid.
The initial response of the inverter in this case is to disconnect itself from the grid. The grid is subsequently checked for the stipulated monitoring period. If no further problem has been detected by the end of this period, then the inverter will resume feeding energy into the grid.

Depending on the country setup, the SoftStart-function GPIS is activated: after cutting out due to an AC fault, the output power of the inverter is continuously increased by 10% every minute in line with the VDE-AR-N 4105 guideline.

102

AC voltage too high

Behaviour Following careful testing and when the grid conditions are within the permissible range again, the inverter will resume feeding energy into the grid.

Remedy Check grid connections
If this status code keeps recurring, contact your system engineer

103

AC voltage too low

Behaviour Following careful testing and when the grid conditions are within the permissible range again, the inverter will resume feeding energy into the grid.

Remedy Check grid connections
If this status code keeps recurring, contact your system engineer

105

AC frequency too high

Behaviour	Following careful testing and when the grid conditions are within the permissible range again, the inverter will resume feeding energy into the grid.
-----------	---

Remedy	Check grid connections If this status code keeps recurring, contact your system engineer
--------	---

106

AC frequency too low

Behaviour	Following careful testing and when the grid conditions are within the permissible range again, the inverter will resume feeding energy into the grid.
-----------	---

Remedy	Check grid connections If this status code keeps recurring, contact your system engineer
--------	---

107

No AC grid

Behaviour	Following careful testing and when the grid conditions are within the permissible range again, the inverter will resume feeding energy into the grid.
-----------	---

Remedy	Check grid connections If this status code keeps recurring, contact your system engineer
--------	---

108

Stand alone operation detected

Behaviour	Following careful testing and when the grid conditions are within the permissible range again, the inverter will resume feeding energy into the grid.
-----------	---

Remedy	If this status code keeps recurring, contact your system engineer
--------	---

Class 3 status codes

Class 3 includes status codes that may occur while feeding energy into the grid, but generally do not cause the process to be interrupted for any length of time.

The inverter disconnects automatically from the grid, the grid is then monitored as specified and the inverter attempts to resume feeding energy into the grid.

301

Overcurrent (AC)

Behaviour Short-term interruption while feeding energy into the grid due to overcurrent in the alternating current circuit
The inverter resumes with its startup routine.

Remedy Fault is rectified automatically
If this status code keeps recurring, contact your system engineer

303

Power module overtemperature

Behaviour Short-term interruption while feeding energy into the grid due to overtemperature
The inverter resumes with its startup routine.

Remedy Purge cooling air openings and heat sink if necessary; fault is rectified automatically
If this status code keeps recurring, contact your system engineer

304

Internal temperature too high

Behaviour Short-term interruption while feeding energy into the grid due to overtemperature
The inverter resumes with its startup routine

Remedy Purge cooling air openings and heat sink if necessary; fault is rectified automatically
If this status code keeps recurring, contact your system engineer

305

If the grid relay is closed, no energy is transferred to the grid

Behaviour Permanent interruption while feeding energy into the grid

Remedy If this status code keeps recurring, contact your system engineer

307 (DC low)

DC input voltage too low for feeding energy into the grid

Behaviour Short-term interruption while feeding energy into the grid
The inverter resumes with its startup routine.

Remedy Fault is rectified automatically
If this status code keeps recurring, contact your system engineer

IMPORTANT! Due to the low level of insolation early in the morning and in the evening, the status code 307 (DC low) is routinely displayed at these times of day. This status code does not indicate any kind of fault.

309

DC input voltage too high

Behaviour Short-term interruption while feeding energy into the grid
The inverter resumes with its startup routine.

Remedy Fault is rectified automatically
If this status code keeps recurring, contact your system engineer

321

Overcurrent (AC)

Behaviour Short-term interruption while feeding energy into the grid due to
a grid fault or a power module fault
The inverter resumes with its startup routine.

Remedy Fault is rectified automatically
If this status code keeps recurring, contact your system engineer

322

Overtemperature on the air intake sensor

Behaviour Permanent interruption while feeding energy into the grid

Remedy Reduce the ambient temperature and ensure that a suitable hot
air extractor is installed if necessary
If this status code keeps recurring, contact your system engineer

Class 4 status codes

Some of the class 4 status codes necessitate intervention by a Fronius-trained service engineer.

401

No communication with power stage set possible

Behaviour The inverter will automatically attempt to connect grid again and, if possible, will resume feeding energy into the grid

Remedy If the status code is displayed all the time: notify a Fronius-trained service engineer

406

Power module temperature sensor defective

Behaviour The inverter is disconnected from the grid for safety reasons.

Remedy If the status code is displayed all the time: notify a Fronius-trained service engineer

407

Internal temperature sensor defective

Behaviour The inverter is disconnected from the grid for safety reasons.

Remedy If the status code is displayed all the time: notify a Fronius-trained service engineer

412

Fixed voltage mode has been selected instead of MPP voltage mode, and the fixing voltage has been set at too low or too high a value.

Behaviour The fixed voltage is lower than the current MPP voltage.

Remedy Check module voltage and change the connection of the solar modules if the input voltage is too high;
If the status code appears all the time: notify a Fronius-trained service engineer

415

External Emergency Stop line is blocked

Behaviour The inverter is disconnected from the grid for safety reasons.

Remedy Fault is rectified automatically;
If this status code keeps recurring: notify a Fronius-trained service engineer

416

No communication possible between power stage set and control system

Behaviour The inverter is disconnected from the grid for safety reasons.

Remedy If the status code is displayed all the time: notify a Fronius-trained service engineer

425

No communication possible with the power module

Behaviour The inverter is disconnected from the grid for safety reasons and then attempts a restart.

Remedy If the status code is displayed all the time: notify a Fronius-trained service engineer

426

Intermediate circuit charging takes too long

Behaviour Short-term interruption while feeding energy into the grid
The inverter resumes with its startup routine.

Remedy Fault is rectified automatically
If this status code keeps recurring, contact your system engineer

427

Power stage set not ready for too long (timeout)

Behaviour Short-term interruption while feeding energy into the grid
The inverter resumes with its startup routine.

Remedy Fault is rectified automatically
If this status code keeps recurring, contact your system engineer

431

Bootloading process interrupted

Behaviour The inverter is in bootloading mode and is not feeding any energy into the grid

Remedy Repeat the update process
If the status code is displayed all the time: notify a Fronius-trained service engineer

436

Receiving incorrect fault information from the power stage set

Behaviour Short-term interruption while feeding energy into the grid
The inverter resumes with its startup routine.

Remedy Fault is rectified automatically
If this status code keeps recurring, contact your system engineer

437

General error handling started in the power stage set

Behaviour Short-term interruption while feeding energy into the grid
The inverter resumes with its startup routine.

Remedy Fault is rectified automatically
If this status code keeps recurring, contact your system engineer

438

Receiving incorrect fault information from the power stage set

Behaviour	Short-term interruption while feeding energy into the grid The inverter resumes with its startup routine.
-----------	--

Remedy	Fault is rectified automatically If this status code keeps recurring, contact your system engineer
--------	---

445

- Compatibility error (e.g. due to replacement of a PC board)
- Invalid power stage set configuration

Behaviour	The inverter is not feeding any energy into the grid.
-----------	---

Remedy	Update the inverter firmware; If the status code is displayed all the time: notify a Fronius-trained service engineer
--------	--

457

Mains relay sticking

Behaviour	The inverter is not feeding any energy into the grid.
-----------	---

Remedy	notify a Fronius-trained service engineer
--------	---

459

Error when recording the measurement signal for the insulation test

Behaviour	The inverter is not feeding any energy into the grid.
-----------	---

Remedy	notify a Fronius-trained service engineer
--------	---

460

Reference voltage source for the digital signal processor (DSP) is working out of tolerance

Behaviour	The inverter is not feeding any energy into the grid.
-----------	---

Remedy	If the status code is displayed all the time: notify a Fronius-trained service engineer
--------	---

461

Fault in the DSP data memory

Behaviour	The inverter is not feeding any energy into the grid.
-----------	---

Remedy	If the status code is displayed all the time: notify a Fronius-trained service engineer
--------	---

463

AC polarity reversed

Behaviour	The inverter is not feeding any energy into the grid.
-----------	---

Remedy	Update the inverter firmware If the status code is displayed all the time: notify a Fronius-trained service engineer
--------	---

472

Fuse for solar module grounding is faulty

Behaviour	The inverter is not feeding any energy into the grid.
-----------	---

Remedy	Replace fuse for solar module grounding - notify a Fronius-trained service engineer; if this status code keeps recurring, contact your system engineer
--------	---

475

Solar module grounding, insulation fault (connection between solar module and ground)

Behaviour	The inverter is disconnected from the grid for safety reasons.
-----------	--

Remedy	If the status code is displayed all the time: notify a Fronius-trained service engineer
--------	---

486

- External NO contact is open
- Optional measuring and monitoring relay has tripped

Behaviour	The inverter is not feeding any energy into the grid.
-----------	---

Remedy	Close external NO contact; check measuring and monitoring relay If this status code keeps recurring, contact your system engineer
--------	---

487

Air inlet temperature sensor is faulty

Behaviour	The inverter is not feeding any energy into the grid.
-----------	---

Remedy	Replace air inlet temperature sensor - notify a Fronius-trained service engineer
--------	--

488

AC measurement device is faulty

Behaviour	The inverter is not feeding any energy into the grid.
-----------	---

Remedy	notify a Fronius-trained service engineer
--------	---

490, 491

Internal communication error

Behaviour The inverter is not feeding any energy into the grid.

Remedy notify a Fronius-trained service engineer

492

DC main switch is switched off

Behaviour The inverter is not feeding any energy into the grid.

Remedy Switch on DC main switch

493

DC relay is faulty

Behaviour The inverter is not feeding any energy into the grid.

Remedy notify a Fronius-trained service engineer

494

Grounding fault on the control board

Behaviour The inverter is not feeding any energy into the grid.

Remedy notify a Fronius-trained service engineer

495

The 3 V supply voltage on the control board is faulty

Behaviour The inverter is not feeding any energy into the grid.

Remedy notify a Fronius-trained service engineer

496

The 5 V supply voltage on the control board is faulty

Behaviour The inverter is not feeding any energy into the grid.

Remedy notify a Fronius-trained service engineer

497

The 14 V or 22 V supply voltage for the PWM driver is faulty

Behaviour The inverter is not feeding any energy into the grid.

Remedy notify a Fronius-trained service engineer

498

The 24 V supply voltage for the power electronics is faulty

Behaviour The inverter is not feeding any energy into the grid.

Remedy notify a Fronius-trained service engineer

499

The 24 V supply voltage on the control board is faulty

Behaviour The inverter is not feeding any energy into the grid.

Remedy notify a Fronius-trained service engineer

Class 5 status codes

Class 5 status codes do not generally interfere with feeding energy into the grid, but can cause restrictions. A status code is displayed until it is acknowledged by pressing a key (the inverter, however, continues to operate normally in the background).

502

Insulation error on the solar modules

Description Warning message is shown on the display

Remedy If the status code is displayed all the time: notify a Fronius-trained service engineer

509

No energy fed into the grid in the past 24 hours

Description Warning message is shown on the display

Remedy Check that all the conditions for feeding energy into the grid without any problems have been satisfied.
If the status code is displayed all the time: notify a Fronius-trained service engineer

516

No communication possible with the storage unit

Description Storage unit warning message

Remedy If the status indicator appears all the time: notify a Fronius-trained service engineer

517

Power derating caused by too high a temperature

Description Warning message when power derating occurs

Remedy If the status indicator appears all the time: notify a Fronius-trained service engineer

518

Internal DSP malfunction

Description Warning message is shown on the display

Remedy If the status indicator appears all the time: notify a Fronius-trained service engineer

535

Error during fan self-test

Description	Warning message is shown on the display
-------------	---

Remedy	If the status indicator appears all the time: notify a Fronius-trained service engineer
--------	---

536

Main fan error

Description	Warning message is shown on the display
-------------	---

Remedy	If the status indicator appears all the time: notify a Fronius-trained service engineer
--------	---

551

Fuse for solar module grounding is faulty

Description	Warning message is shown on the display
-------------	---

Remedy	Replace fuse for solar module grounding - notify a Fronius-trained service engineer; if this status code keeps recurring, contact your system engineer
--------	--

555

Circulating fan error

Description	Warning message is shown on the display
-------------	---

Remedy	If the status indicator appears all the time: notify a Fronius-trained service engineer
--------	---

558

Functional incompatibility (one or more PC boards in the inverter are not compatible with each other, e.g. after a PC board has been replaced)

Description	Possible device errors or malfunctions on the inverter
-------------	--

Remedy	Update the inverter firmware using the Fronius Solar.update software; the latest inverter firmware is available from http://www.fronius.com . If the status indicator appears all the time: notify a Fronius-trained service engineer
--------	--

560

Power derating caused by overfrequency

Description	The status code is displayed from a grid frequency of 50.2 Hz and above. The inverter reduces the power along a 40%/Hz slope. The inverter switches off at a grid frequency of 51.5 Hz. The status indicator is displayed until the inverter returns to normal operation.
Remedy	From a frequency of 50.2 Hz and above, the inverter tries to reconnect to the grid. The fault is rectified automatically as soon as the inverter returns to normal operation. If the status indicator appears all the time: notify a Fronius-trained service engineer

597

External overvoltage protection has tripped (connected to the "IN1" NO/alarm contact terminals)

Description	Warning message is shown on the display
Remedy	Replace overvoltage protection - notify a Fronius-trained service engineer

598

External overvoltage protection has tripped (connected to the "IN2" NO/alarm contact terminals)

Description	Warning message is shown on the display
Remedy	Replace overvoltage protection - notify a Fronius-trained service engineer

599

External overvoltage protection has tripped (connected to the "IN3" NO/alarm contact terminals)

Description	Warning message is shown on the display
Remedy	Replace overvoltage protection - notify a Fronius-trained service engineer

Class 7 status codes

Class 7 status codes relate to the control system, the configuration and inverter data recording, and may directly or indirectly affect the process of feeding energy into the grid.

701 - 716

Provides information about the internal processor program status

Description	Is of no concern when the inverter is working properly and only appears in the "Status PS" setup parameter. In the event of an actual error, this status code supports Fronius TechSupport during the error analysis.
-------------	---

721

EEPROM has been re-initialised

Description Warning message is shown on the display

Remedy If the status code is displayed all the time: notify a Fronius-trained service engineer

722 - 730

Provides information about the internal processor program status

Description Is of no concern when the inverter is working properly and only appears in the "Status PS" setup parameter. In the event of an actual error, this status code supports Fronius TechSupport during the error analysis.

751

Time lost

Description Warning message is shown on the display

Remedy Reset the time and date
If the status code is displayed all the time: notify a Fronius-trained service engineer

752

Real Time Clock module faulty

Description Warning message is shown on the display

Remedy Reset the time and date
If the status code is displayed all the time: notify a Fronius-trained service engineer

753

Time not set for a long period (> 1/2 year)

Description Warning message is shown on the display

Remedy Reset the time and date
If the status code is displayed all the time: notify a Fronius-trained service engineer

754, 755

Provides information about the internal processor program status

Description Is of no concern when the inverter is working properly and only appears in the "Status PS" setup parameter. In the event of an actual error, this status code supports Fronius TechSupport during the error analysis.

757

Hardware error in the Real Time Clock module

Description Warning message is shown on the display; the inverter is not feeding any energy into the grid

Remedy If the status code is displayed all the time: notify a Fronius-trained service engineer

761 - 765

Provides information about the internal processor program status

Description Is of no concern when the inverter is working properly and only appears in the "Status PS" setup parameter. In the event of an actual error, this status code supports Fronius TechSupport during the error analysis.

766

Emergency derating has been activated (max. 750 W)

Description Warning message is shown on the display

Remedy If the status code is displayed all the time: notify a Fronius-trained service engineer

767

Provides information about the internal processor program status

Description Is of no concern when the inverter is working properly and only appears in the "Status PS" setup parameter. In the event of an actual error, this status code supports Fronius TechSupport during the error analysis.

768

Different power derating in the hardware modules

Description Warning message is shown on the display

Remedy If the status code is displayed all the time: notify a Fronius-trained service engineer

772

Storage unit not available

Description Warning message is shown on the display

Remedy If the status code is displayed all the time: notify a Fronius-trained service engineer

773

Software update group 0 (invalid country setup)

Description Warning message is shown on the display

Remedy If the status code is displayed all the time: notify a Fronius-trained service engineer

775
 PMC power stage set not available

Description	Warning message is shown on the display
Remedy	Press the 'Enter' key to acknowledge the error If the status code is displayed all the time: notify a Fronius-trained service engineer

776
 Invalid device-type

Description	Warning message is shown on the display
Remedy	Press the 'Enter' key to acknowledge the error If the status code is displayed all the time: notify a Fronius-trained service engineer

781 - 794
 Provides information about the internal processor program status

Description	Is of no concern when the inverter is working properly and only appears in the "Status PS" setup parameter. In the event of an actual error, this status code supports Fronius TechSupport during the error analysis.
-------------	---

799
 No communication between the control board and the monitoring board

Behaviour	The inverter is not feeding any energy into the grid.
Remedy	notify a Fronius-trained service engineer

Class 10 - 12 status codes

1000 - 1299- Provide information on the status of the internal processor program	
Description	Is of no concern when the inverter is working properly and only appears in the "Status PS" setup parameter. In the event of an actual error, this status code assists Fronius Technical Support during the error analysis.

Customer service

- IMPORTANT!** Contact your Fronius dealer or a Fronius-trained service technician if
- an error appears frequently or all the time
 - an error appears that is not listed in the tables

Maintenance

Safety



WARNING! An electric shock can be fatal. Danger due to grid voltage and DC voltage from solar modules.

- The DC main switch is only to be used to de-energise the power stage set. The connection compartment is still live when the DC main switch is switched off.
- Work in the connection compartment must only be carried out by qualified electricians.
- Maintenance and servicing in the power stage set of the inverter must only be carried out by Fronius-trained service technicians.



WARNING! An electric shock can be fatal. Danger due to residual voltage in capacitors.

Wait for the capacitors to discharge. Discharge time is 10 minutes.

Maintenance guidelines

To ensure that the inverter keeps working perfectly, the following maintenance activities must be carried out every year:

- To prevent defects occurring in the electronic components, check the inverter for dirt, dust or moisture.
- Re-tighten the DC and AC cable terminals to the specified torque
- Check that the installed inverter software is up-to-date and update the software if necessary
- Either in the Setup menu or using the Fronius Solar.Service software, run the main fan test to test that the air supply is working properly.

Fronius offers an optional maintenance contract for the inverter that includes annual maintenance by a Fronius engineer.

More information can be found on the Fronius Homepage at <http://www.fronius.com>.

Replacement of components

The following components should be replaced after 10 years:

- main fan
- circulating fan (next to the power stage set)
- MENT PC board (switched mode power supply)

Replacement of components in accordance with the Fronius Agilo Service Manual; apply to the relevant TechSupport for components.

Opening the inverter for maintenance work

When the inverter must be opened for maintenance work, carry out the following procedures:

- 1 De-energise the AC and DC side of the inverter
- 2 Switch off the DC main switch
- 3 Wait for the capacitors to discharge (10 minutes)
- 4 Open the door and air inlet grilles
- 5 Remove covers and/or contact protection
- 6 If present, remove fuse for solar module grounding

Operation in environments subject to heavy accumulations of dust

When operating in environments subject to heavy accumulations of dust: if necessary, purge the filter grilles on the fans using clean compressed air.

IMPORTANT! Do not blow dust and impurities into the inverter.

Replacing fuses

Safety



WARNING! An electric shock can be fatal. Danger due to grid voltage and DC voltage from solar modules.

- Make sure that both the AC side and the DC side of the inverter are de-energised before making any connections or carrying out maintenance work.
- The connection compartment must only be opened by an qualified electrical engineer.
- The power stage set may only be opened by Fronius-trained service technicians.



WARNING! An electric shock can be fatal. Danger due to residual voltage in capacitors.

Wait for the capacitors to discharge. Discharge time is 5 minutes.



WARNING! An electric shock can be fatal. Danger from DC voltage in solar modules.

The DC main switch is only to be used to de-energise the power stage set. Grounding of the solar module remains in effect, even when the DC main switch is switched off. Do not under any circumstances touch DC+ or DC-.



WARNING! An electric shock can be fatal. If a ground fault occurs, a conductor that is normally grounded can lose its ground connection and become live. A ground fault must be repaired before operation is resumed.



WARNING! An inadequate ground conductor connection can cause serious injury or damage.

The screws on the covers provide a suitable ground conductor connection for the housing; these screws must not under any circumstances be replaced by other screws that do not provide a reliable ground conductor connection.

Replacing the reverse polarity protection fuse

The inverter has been activated with the polarity of the DC cables reversed. Despite sufficient levels of insolation, status code 307 "DC low" appears on the display.

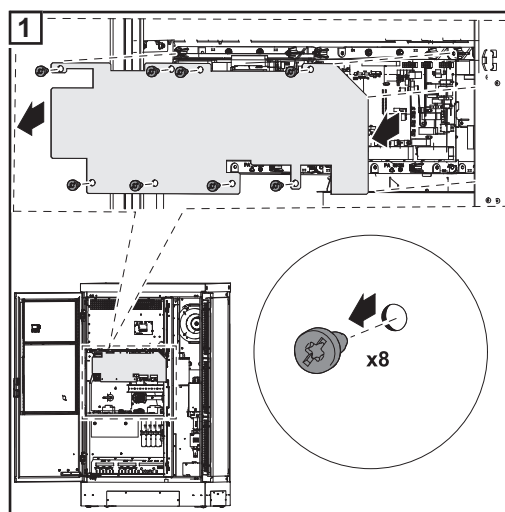

- Remove the contact protection above the data communication area

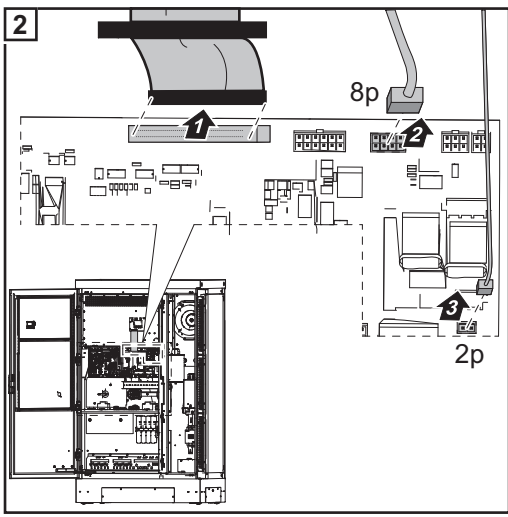

- Unplug the ribbon cable
- Unplug the 8-pin Molex plug (8p)
- Unplug the 2-pin Molex plug (2p)

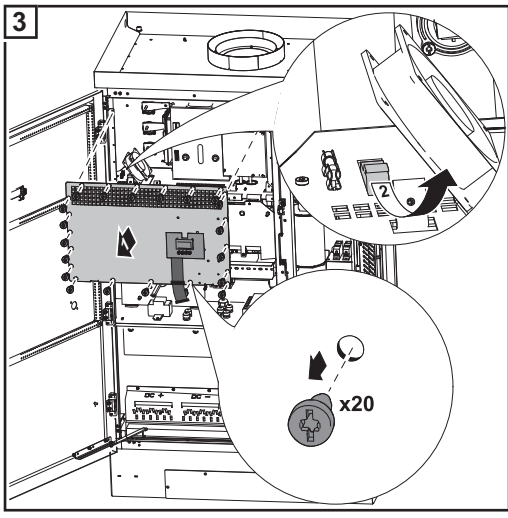

- Remove 20 screws
- Pull out the bottom cover and remove from the front
- Open the fuse holder underneath the fan

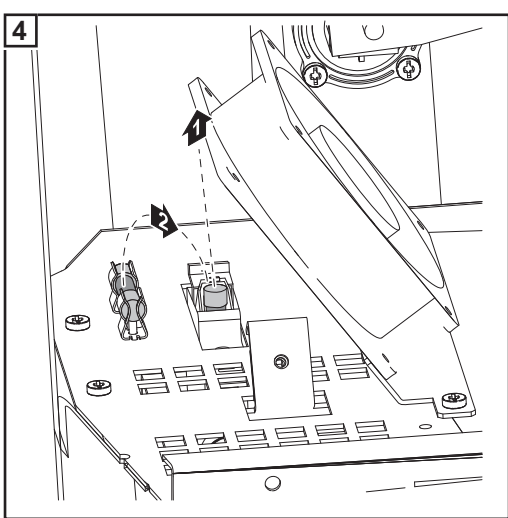

- Fit the spare fuse in the fuse holder

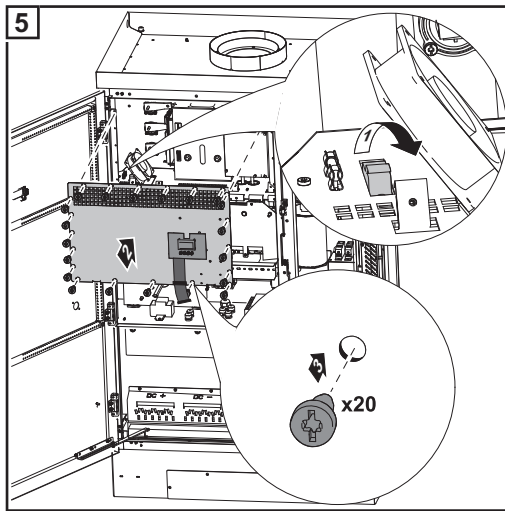

- Close the fuse holder
- Fit the cover
- Fix the cover in place using 20 screws

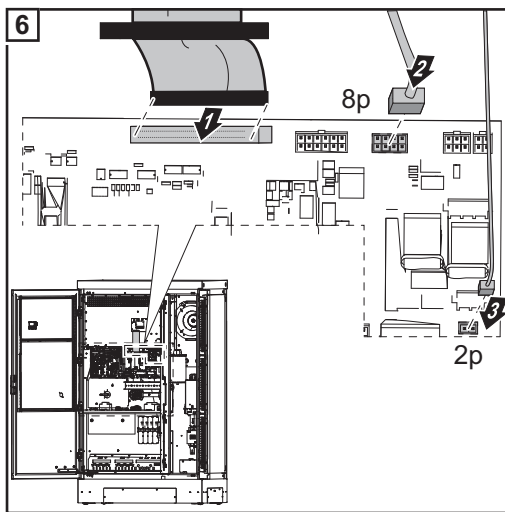

- Connect the ribbon cable
- Connect the 8-pin Molex plug (8p)
- Connect the 2-pin Molex plug (2p)

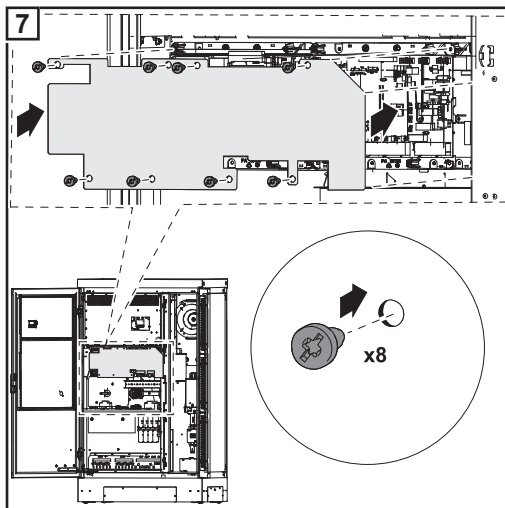

- Fit the contact protection above the data communication area

Appendix

Technical data

Fronius Agilo 75.0-3

Input data

MPP voltage range	460 - 820 V DC
Max. input voltage (at 1000 W/m ² / -10 °C in an open circuit)	950 V DC
Max. input current	170,0 A
Max. short circuit current of the solar modules	255,0 A

Output data

Nominal output power (P_{nom})	75 kVA
Max. output power	75 kVA
Nominal grid voltage	3 ~ NPE 400 V / 230 V
Grid voltage tolerance	+10 / -5 % ¹⁾
Nominal output current (three-phase)	112,4 A
Nominal frequency	50 - 60 Hz ¹⁾
Total harmonic distortion	< 3 %
Power factor cos phi	1 0,8 - 1 ind./cap. ²⁾
Max. permitted mains impedance Z_{max} at PCC ³⁾	66 mOhm
Max. feedback current ⁴⁾	0 A ⁵⁾
Starting current pulse ⁶⁾	0 A ⁵⁾
Max. output fault current per period	522 A / 2,47 ms

General data

Maximum efficiency	97,3 %
Europ. efficiency	96,7 %
Overnight internal consumption	36 W
Cooling	Controlled forced-air ventilation
Degree of protection	IP 30
Dimensions l x w x h	1100 x 700 x 1884 mm
Weight	760 kg
Permitted ambient temperature (at 95% rel. humidity)	- 20 °C - +50 °C
EMC emission class	A
Over-voltage category AC / DC	3 / 2
Degree of pollution	3

Protection devices

DC insulation measurement	Warning/shutdown ⁷⁾ at $R_{ISO} < 40$ kOhm
Manifestation of DC overload	Operating point shift power limitation
DC circuit breaker	Integrated

**Fronius Agilo
100.0-3**

Input data

MPP voltage range	460 - 820 V DC
Max. input voltage (at 1000 W/m ² / -10 °C in an open circuit)	950 V DC
Max. input current	227.0 A
Max. short circuit current of the solar modules	340.5 A

Output data

Nominal output power (P _{nom})	100 kVA
Max. output power	100 kVA
Nominal grid voltage	3 ~ NPE 400 V / 230 V
Grid voltage tolerance	+10 / -5 % ¹⁾
Nominal output current (three-phase)	150.2 A
Nominal frequency	50 - 60 Hz ¹⁾
Total harmonic distortion	< 3 %
Power factor cos phi	1 0.8 - 1 ind./cap. ²⁾
Max. permitted mains impedance Z _{max} at PCC ³⁾	52 mOHM
Max. feedback current ⁴⁾	0 A ⁵⁾
Starting current pulse ⁶⁾	0 A ⁵⁾
Max. output fault current per period	522 A / 2.47 ms

General data

Maximum efficiency	97.2 %
Europ. efficiency	96.6 %
Overnight internal consumption	36 W
Cooling	Controlled forced-air ventilation
Degree of protection	IP 30
Dimensions l x w x h	1100 x 700 x 1884 mm
Weight	834 kg
Permitted ambient temperature (at 95% rel. humidity)	- 20 °C - +50 °C
EMC emission class	A
Over-voltage category AC / DC	3 / 2
Degree of pollution	3

Protection devices

DC insulation measurement	Warning/shutdown ⁷⁾ at R _{ISO} < 31.66 kOhm
Manifestation of DC overload	Operating point shift power limitation
DC circuit breaker	Integrated

Explanation of footnotes

- 1) The values quoted are default values; the inverter is configured specifically to meet the needs of the country in question.
- 2) Depending on the country setup or device-specific settings (ind. = inductive; cap. = capacitive)
- 3) PCC = interface to the public grid
- 4) Maximum current from the inverter to the solar module when an error occurs in the inverter or when the insulation between the AC and DC side is defective
- 5) Guaranteed by the electrical configuration of the inverter
- 6) Current peak when switching on the inverter
- 7) Depending on the country setup

Applicable standards and guidelines

CE mark The devices comply with all the requisite and relevant standards and guidelines that form part of the relevant EU Directive, and are therefore permitted to display the CE mark.

Parallel operation of in-plant generation systems The inverter complies with the

- "guidelines for connection and parallel operation of in-plant generation systems with the low-voltage grid" published by the German Electricity Industry Association (VDEW)
- "technical guidelines for parallel operation of in-plant generation systems" published by the Austrian Association of Electricity Companies

Power failure The standard measurement and safety procedures integrated into the inverter ensure that in the event of a grid failure, the feeding in of energy is immediately interrupted (e.g. switch-off by the energy supplier or damage to lines).

Exception: when the LVFRT function is activated

Warranty terms and conditions, and disposal

Fronius manufacturer's warranty

When the Fronius inverters are delivered, they come with a manufacturer's warranty that is valid worldwide for 60 months from the date of installation. This can be extended for an additional payment.

While the warranty is in force, Fronius will ensure that the inverter is working properly. The detailed, country-specific warranty terms and conditions are available from the engineer installing the system, or on the Internet at the following address:
<http://www.fronius.com/solar/servicebasic/de>

To make a claim under the Fronius manufacturer's warranty, the relevant product invoice, the Service Basic terms and conditions and, if applicable, proof of payment from when the warranty was extended, must be submitted.

Fronius therefore recommends that once the inverter has been commissioned, you print out an up-to-date copy of the Service Basic terms and conditions.

Disposal

If you decide in the future to replace your inverter, Fronius will take back the old device and arrange for it to be recycled in an appropriate manner.



**EG-KONFORMITÄTSERKLÄRUNG 2013
EC-DECLARATION OF CONFORMITY 2013
DECLARATION DE CONFORMITE DE LA CE, 2013**

Wels-Thalheim, 2013-03-04

Die Firma

Manufacturer

La compagnie

FRONIUS INTERNATIONAL GMBH
Günter Fronius Straße 1, A-4600 Wels-Thalheim

erklärt in alleiniger Verantwortung,
dass folgendes Produkt:

Hereby certifies on its sole
responsibility that the following
product:

se déclare seule responsable du fait
que le produit suivant:

Fronius Agilo 100.0-3 / 75.0-3
Solar-Wechselrichter

Fronius Agilo 100.0-3 / 75.0-3
Photovoltaic inverter

Fronius Agilo 100.0-3 / 75.0-3
Onduleur solaire

auf das sich diese Erklärung
bezieht, mit folgenden Richtlinien
bzw. Normen übereinstimmt:

which is explicitly referred to by this
Declaration meet the following
directives and standard(s):

qui est l'objet de la présente
déclaration correspondent aux
suivantes directives et normes:

Richtlinie 2006/95/EG
Elektrische Betriebsmittel
Niederspannungsrichtlinie

Directive 2006/95/EC
Electrical Apparatus
Low Voltage Directive

Directive 2006/95/CE
Outillages électriques
Directive de basse tension

Richtlinie 2004/108/EG
Elektromag. Verträglichkeit

Directive 2004/108/EC
Electromag. compatibility

Directive 2004/108/CE
Électromag. Compatibilité

Europäische Normen inklusive
zutreffende Änderungen
IEC 62109-1:2010
EN 61000-6-4:2007
EN 61000-6-2:2005
EN 61000-3-12:2005

European Standards including
relevant amendments
IEC 62109-1:2010
EN 61000-6-4:2007
EN 61000-6-2:2005
EN 61000-3-12:2005

Normes européennes avec
amendements correspondants
IEC 62109-1:2010
EN 61000-6-4:2007
EN 61000-6-2:2005
EN 61000-3-12:2005

Die oben genannte Firma hält
Dokumentationen als Nachweis der
Erfüllung der Sicherheitsziele und
die wesentlichen Schutzanforder-
ungen zur Einsicht bereit.

Documentation evidencing
conformity with the requirements of
the Directives is kept available for
inspection at the above
Manufacturer.

En tant que preuve de la satisfaction
des demandes de sécurité la
documentation peut être consultée
chez la compagnie susmentionnée.

CE 2013

ppa. Mag Ing.H.Hackl

Fronius Worldwide - www.fronius.com/addresses

Fronius International GmbH
4600 Wels, Froniusplatz 1, Austria
E-Mail: pv-sales@fronius.com
<http://www.fronius.com>

Fronius USA LLC Solar Electronics Division
6797 Fronius Drive, Portage, IN 46368
E-Mail: pv-us@fronius.com
<http://www.fronius-usa.com>

Under <http://www.fronius.com/addresses> you will find all addresses of our sales branches and partner firms!

